

# brother

## PARTS BOOK

**BAS-150**

**P150002**





Automatic Sleeve Easing Machine



**BROTHER INDUSTRIES, LTD.**  
**NAGOYA, JAPAN**

1950



## Notes for using this parts book

1. If the symbol  is found in the "Parts No." column or the "Assembly No." column, refer to the different parts list on page 15.
2. The symbol  in the "Parts No." column indicates that the Parts is not available for supply. If, however, there is a number in the "Assembly No." column, the parts can be ordered as an assembly. Please, therefore, order by using the assembly number.
3. This book was prepared based on information available in March, 1982.
4. Parts are subject to changes in design without prior notice.

## Anmerkungen zum Gebrauch dieses Stücklistebuches

1. Dieses Zeichen  in der Spalte "Parts No. (Teilnummer)" oder "Assembly No. (Gerätesatznummer)" verweist auf die Gesonderte Stückliste auf Seite 15.
2. Dieses Zeichen  in der Spalte "Teilnummer" bedeutet, daß dieser Teil nicht lieferbar ist. Wenn jedoch in der Spalte "Gerätesatznummer" eine Nummer steht, kann dieser Teil als ein Geräteteilsatz bestellt werden. Bestellen Sie daher bitte mit dieser Gerätesatznummer.
3. Dieses Buch basiert auf den Informationen vom März, 1982.
4. Modelländerungen sind vorbehalten.

## Notes sur l'utilisation de ce manuel de pièces détachées

1. Si le symbole  se trouve dans la colonne "Parts No. (N° de pièce)" ou dans la colonne "Assembly No. (N° jeu de pcs)", veuillez vous référer à la liste de pièces annexe page 15.
2. Le symbole  dans la colonne "N° de pièce" signifie que la pièce ne peut être fournie. Si, dans la colonne "N° jeu de pcs", il y a un numéro de nomenclature, la pièce peut être commandée comme faisant partie d'un jeu de pièces. Donc, pour toute commande, veuillez spécifier le N° de jeu de pièces.
3. Ce manuel a été fait d'après les renseignements valables au mois de Mars 1982.
4. Les pièces peuvent être sujettes à des modifications sans préavis.

## Notas para usar este Libro de Piezas

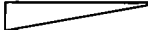
1. De haber un símbolo  junto al "Parts No. (Número de Pieza)" o en la columna del "Assembly No. (Número de Juego)", habrá que mirar la lista de piezas separada de la página 15.
2. El símbolo , que se encuentra en la columna del "Número de Pieza", quiere decir que no se dispone de dicha pieza sola. Cuando, empero, hay un número en la columna del "Numero de Juego", se podrá ordenar la pieza con todo el juego. Por lo tanto, será mejor hacer el pedido recurriendo al número del juego respectivo.
3. Este libro ha sido compilado basándose en los datos de que se disponía en marzo de 1982.
4. Las piezas quedan sujetas a cambios de diseño sin aviso previo.

## CONTENTS

A. Machine Body .....	1
B. Needle Bar and Lower Knift Mechanism .....	2
C. Crank Shaft and Synchronizer Mechanism .....	3
D. Double Chain Stitch Looper Mechanism .....	4
E. Feed Mechanism (1) .....	5
E. Feed Mechanism (2) .....	6
F. Presser Foot Mechanism .....	7
G. Lubrication .....	8
H. Chain Cutter and Threading .....	9
J. Cloth Control System and Control Box Mechanism .....	10
K. Air Pressure Mechanism .....	11
L. Power Supply Equipment Mechanism .....	12
M. Table Unite .....	13
Z. Accessories .....	14
DIFFERENT PARTS LIST .....	15
INDEX .....	16

# A. Machine Body

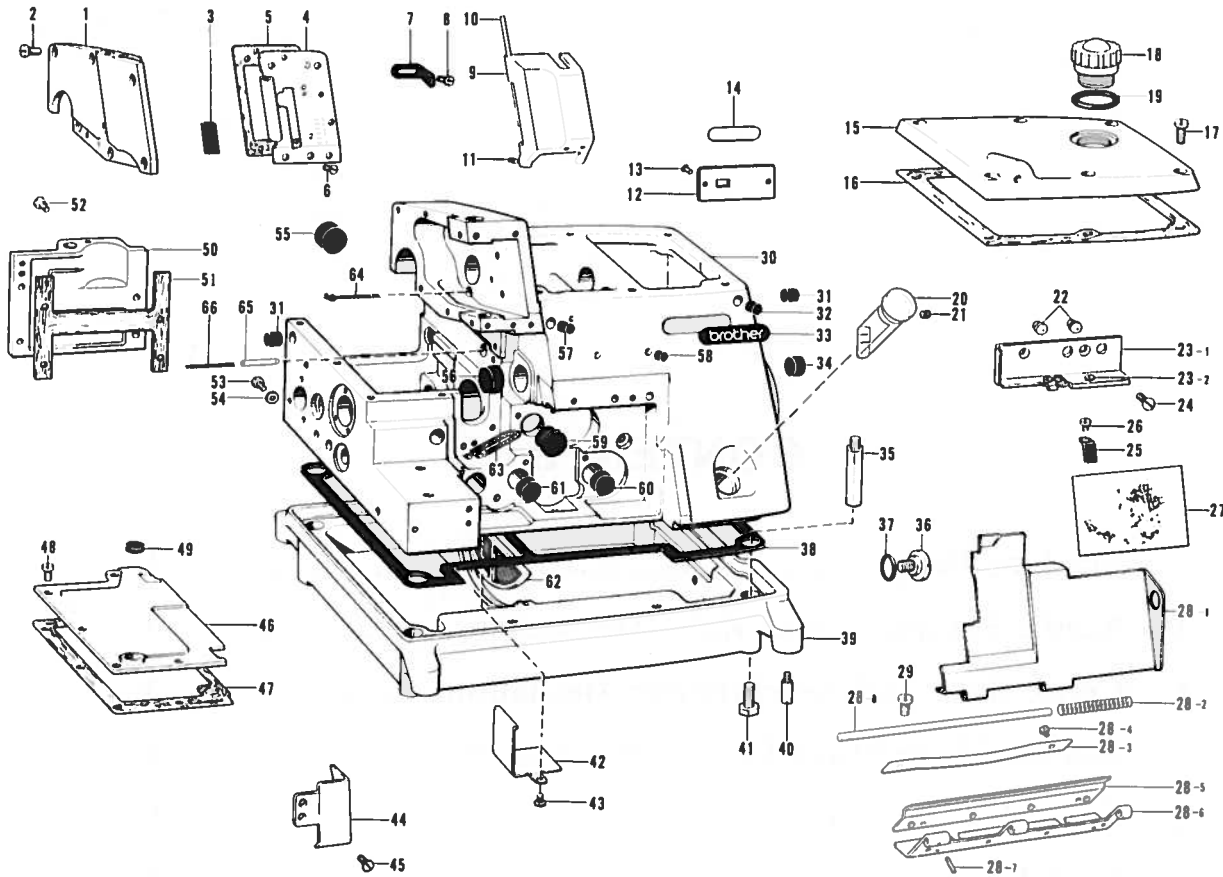

Ref. No.	Name of Parts	Q ty	Parts No.	Assembly No.	Ref. No.	Name of Parts	Q ty	Parts No.	Assembly No
A-1	Cover for Needle Driving Mechanism	1	146422-0-01		A-29	Screw 4.37	2	107407-0-03	
A-2	Screw 4.37 x 7	6	009680-7-12		A-30	Machine Body			
A-3	Rubber Cap	1	143992-0-01		A-31	Oil Cap	2	146315-0-00	
A-4	Face Plate Assembly	1	146428-0-01		A-32	Oil Cap	3	140327-0-01	
A-5	Face Plate Packing	1	146433-0-00		A-33	Name Plate	2		
A-6	Screw 3.57	3	102843-0-04		A-34	Oil Cap	1	140065-0-01	
A-7	Stopper Spring	1	146432-0-01		A-35	Machine Body Leg	4	151059-0-01	
A-8	Screw 3.57 x 6	2	009670-6-12		A-36	Screw 9.52	1	110641-0-01	
A-9	Face Plate Cover	1	146425-0-01		A-37	Packing	1	109203-0-01	
A-10	Pin for Face Plate	1	146426-0-00		A-38	Packing	1	151060-0-00	
A-11	Screw 3.18	1	146427-0-01		A-39	Oil Reservoir	1	146458-0-01	
A-12	Model Plate	1			A-40	Set Pin for Cushion	2	140077-0-01	
A-13	Pin	2			A-41	Bolt 6.35 x 16	4	017771-6-12	
A-14	Parts Book Number Plate	1			A-42	Oil Stopper Plate	1	146457-0-01	
A-15	Top Cover	1	146419-0-01		A-43	Screw 3.57 x 6	2	009670-6-12	
A-16	Packing	1	146420-0-00		A-44	Front Cover Guide	1	159393-0-01	
A-17	Screw 4.37 x 14	6	009681-4-12		A-45	Screw 3.57 x 6	2	003670-6-14	
A-18	Cap for Oil Feeding Hole	1	146421-0-00		A-46	Cover for Feed Mechanism	1	146434-0-00	
A-19	Packing	1	113589-0-01		A-47	Packing	1	146435-0-00	
A-20	Oil Gauge	1	148084-0-01		A-48	Screw 4.37 x 7	5	009680-7-12	
A-21	Screw 4.37 x 4	1	04680-4-22		A-49	Cloth Plate Cushion (B)	1	111486-0-01	
A-22	Oil Cap	2	143196-0-01		A-50	Cover for Feed Mechanism (B)	1	146423-0-01	
A-23-1	Supporter for Front Cover	1		A-23 Supportor for Front Cover Assembly 146444-0-01	A-51	Packing	1	146424-0-00	
A-23-2	Thread Bushing	2	146924-0-00		A-52	Screw 4.37 x 10	4	009681-0-12	
A-24	Screw 4.37	2	117160-0-01		A-53	Screw 4.37 x 7	1	009680-7-12	
A-25	Stopper Spring for Front Cover	1	146446-0-01		A-54	Washer	1	113431-0-02	
A-26	Screw 3.57 x 4.5	1	123185-0-01		A-55	Oil Cap	2	140066-0-01	
A-27	Threading Diagram	1	146463-0-01		A-56	Oil Cap	1	156887-0-01	
A-28-1	Front Cover	1		A-28 Front Cover Assembly 148997-0-01	A-57	Oil Cap	2	140421-0-01	
A-28-2	Spring	1	146442-0-01		A-58	Oil Cap	5	142274-0-01	
A-28-3	Hinge Cover Presser Plate	1	152194-0-01		A-59	Oil Cap	1	108520-0-01	
A-28-4	Screw 3.57 x 4	2	009670-4-12		A-60	Oil Cap	1	154841-0-01	
A-28-5	Hinge Cover	1	148984-0-01		A-61	Oil Cap	1	156886-0-01	
A-28-6	Front Cover Hinge	1	146440-0-01		A-62	Oil Filter	1	145664-0-01	
A-28-7	Spring Pin 1.4 x 8	1	047140-8-42		A-63	Wick	1	147361-0-00	
A-28-8	Shaft for Front Cover	1	146441-0-00		A-64	Wick	1	150307-0-00	
					A-65	Oil Pipe	1	147217-0-00	
					A-66	Wick	1	112735-0-00	



## C. Crank Shaft and Synchronizer Mechanism

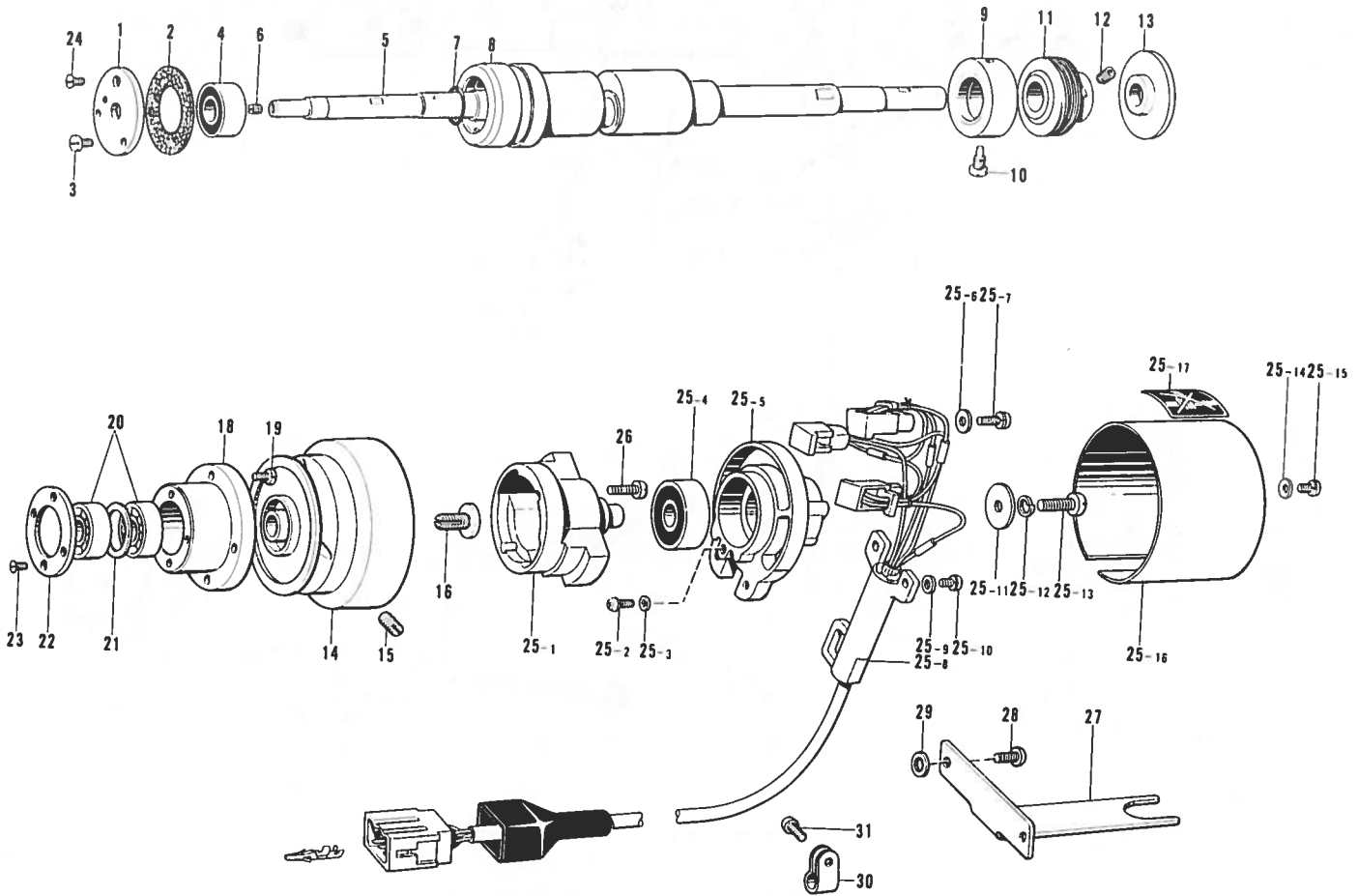

Ref. No.	Name of Parts	Q'ty	Parts No.	Assembly No.	Ref. No.	Name of Parts	Q'ty	Parts No.	Assembly No.
C- 1	Bearing Cap	1	150806-0-01		C-25- 1	Magnet Stud Assembly	1		
C- 2	Packing	1	143312-0-00		C-25- 2	Screw 3 x 6D	1	215083-0-01	
C- 3	Screw 3.57 x 8	2	009670-8-12		C-25- 3	Washer 3	1	025030-3-35	
C- 4	Bearing 6000	1	072600-0-00		C-25- 4	Bearing 6201VV	1		
C- 5	Crank Shaft	1	*156888-0-01		C-25- 5	Synchronizer Holder	1		
C- 6	Screw 4.76	2	013719-4-12		C-25- 6	Washer 4	3	025040-3-35	
C- 7	Packing	1	114294-0-01		C-25- 7	Screw 4 x 12D	3	217093-0-01	
C- 8	Crank Shaft Bushing (L) Assembly	1	146473-0-01		C-25- 8	Hole I.C. with Cord	1		C-25 Synchronizer Assembly #6 - 1 220067-0-01
C- 9	Crank Shaft Bushing, Middle	1	143179-0-00		C-25- 9	Washer 4	2	025040-1-35	
C-10	Screw 4.76	1	110668-0-01		C-25-10	Screw 4 x 10D	2	215080-0-01	
C-11	Worm	1	146647-0-01		C-25-11	Washer 6	1	025060-3-35	
C-12	Screw 6.35 x 6	2	014770-6-22		C-25-12	Washer 2-6	1	028060-2-43	
C-13	Oil Rejector	1	140084-0-00		C-25-13	Screw 6 x 16	1	216880-0-01	
C-14	Pulley	1	151068-0-01		C-25-14	Washer 4	2	025040-1-35	
C-15	Screw 5.95	2	013761-4-10		C-25-15	Screw 4 x 10D	2	215080-0-01	
C-16	Cap Screw	1	140180-0-01		C-25-16	Synchronizer Cover	1		
C-17	Pulley Cover	1	147415-0-01		C-25-17	Label	1		
C-18	Bearing Case	1	110670-0-00		C-26	Screw 4.76 x 14	2	009711-4-12	
C-19	Screw 4.37 x 10	4	009681-0-12		C-27	Synchronizer Holder Plate	1	157992-0-01	
C-20	Bearing 6001	2	072600-1-00		C-28	Screw 4.37 x 10	2	009681-0-12	
C-21	Thrust Washer	1	110672-0-00		C-29	Washer	2	113431-0-02	
C-22	Bearing Cover	1	110673-0-00		C-30	Cord Holder	1	149547-0-00	
C-23	Screw 3.18	4	107244-0-01		C-31	Screw 5 x 10	1	002501-0-03	
C-24	Screw 3.57	1	102538-0-02						



## D. Double Chain Stitch Loper Mechanism

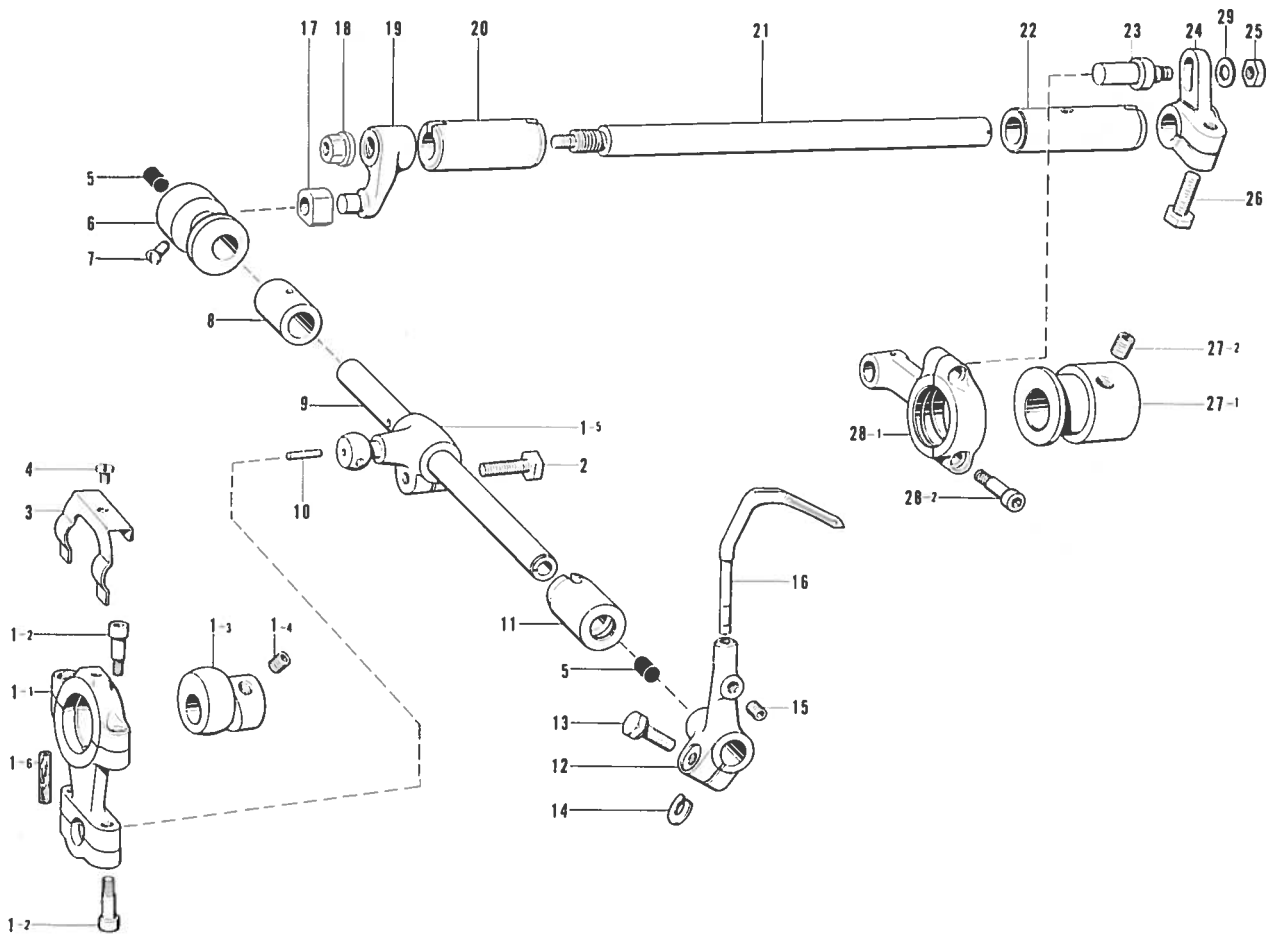

Ref. No.	Name of Parts	Q'ty	Parts No.	Assembly No.	Ref. No.	Name of Parts	Q'ty	Parts No.	Assembly No.
D- 1-1	Longitudinal Feed Rod	1		D-1 Longitudinal Feed Rod Assembly 146618-0-01	D-16	Double-Chain Stitch Loper	1	146635-0-01	
D- 1-2	Screw 4.37 x 14	4	148425-0-01		D-17	Slide Block	1	140313-0-01	
D- 1-3	Longitudinal Eccentric Cam (Left)	1			D-18	Nut 5.56	1	110778-0-02	
D- 1-4	Screw 6.35 x 6	2	014770-6-22		D-19	Feed Lever (Left)	1	146630-0-01	
D- 1-5	Bolt Joint	1			D-20	Bushing (Left)	1	146629-0-00	
D- 1-6	Felt	1	147691-0-00		D-21	Longitudinal Feed Lever Shaft	1	146628-0-01	
D- 2	Bolt 6.35 x 16	1	017771-6-12		D-22	Bushing (Right)	1	140150-0-00	
D- 3	Looper Connecting Rod Stopper	1	146622-0-01		D-23	Pin	1	146627-0-01	
D- 4	Screw 3.18 x 4	1	009660-4-12		D-24	Feed Lever (Right)	1	146626-0-01	
D- 5	Oil Cap	2	140327-0-01		D-25	Nut 4.76	1	110161-0-06	
D- 6	Longitudinal Feed Cam	1	146631-0-01		D-26	Bolt 6.35 x 16	1	017771-6-12	
D- 7	Screw 4.37	2	120990-0-01		D-27-1	Longitudinal Eccentric Cam (Right)	1		D-27 Eccentric Cam (Right) Assembly 147988-0-01
D- 8	Bushing (Rear)	1	146633-0-00		D-27-2	Screw 6.35 x 6	2	014770-6-22	
D- 9	Longitudinal Feed Shaft	1	146632-0-01		D-28-1	Longitudinal Feed Driving Rod	1		D-28 Longitudinal Feed Driving Rod Assembly 146624-1-01
D-10	Pin	1	147318-0-00		D-28-2	Screw 4.37 x 14	2	148425-0-01	
D-11	Bushing (Front)	1	140159-0-00	D-29	Washer 4.76	1	153484-0-01		
D-12	Chain Stitch Loper Holder	1	146634-0-01						
D-13	Bolt 5.56 x 14	1	149171-0-01						
D-14	Spacer	1	148782-0-01						
D-15	Screw 4.37 x 4	1	014680-4-22						

# E. Feed Mechanism (I)

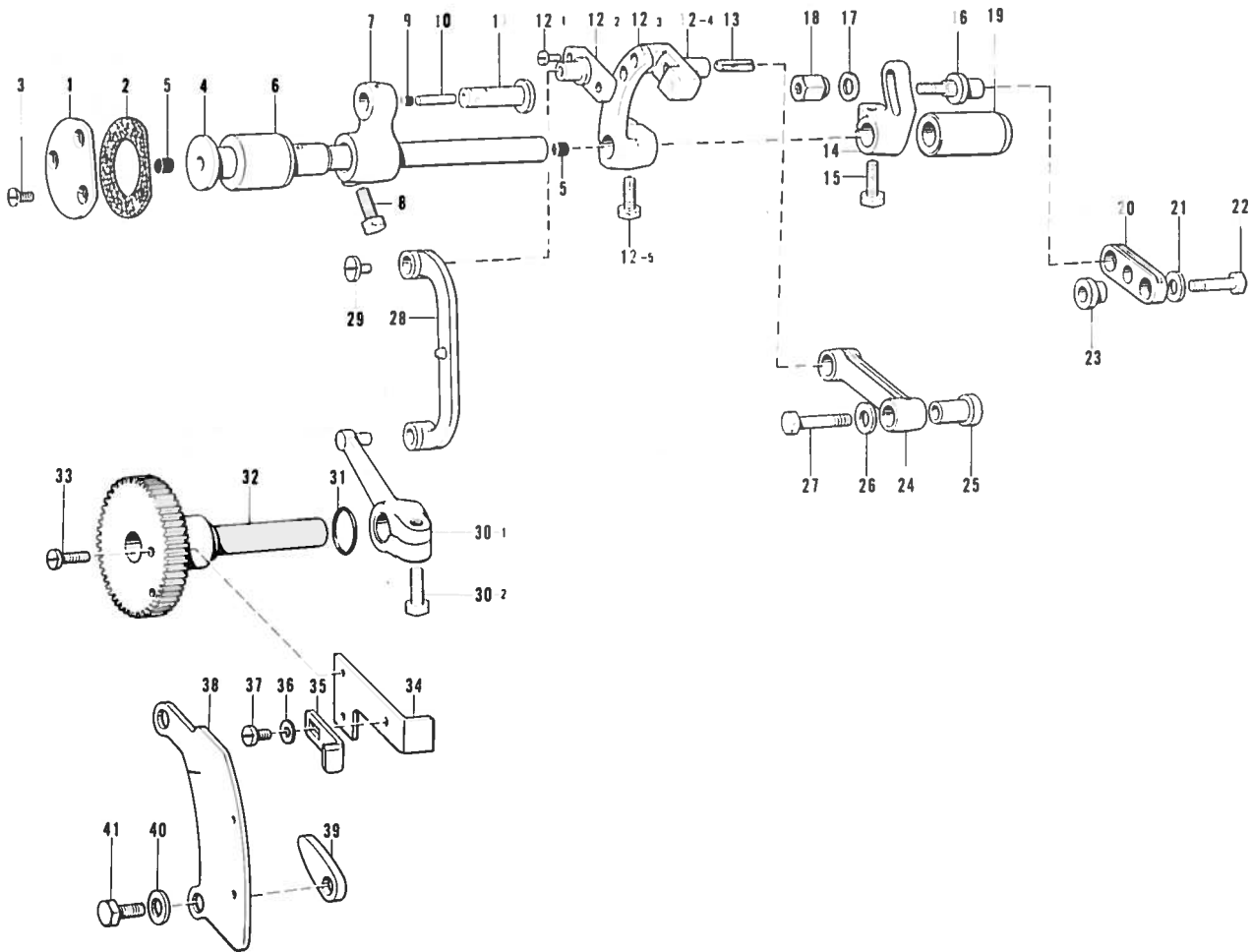

Ref. No.	Name of Parts	Q'ty	Parts No.	Assembly No.	Ref. No.	Name of Parts	Q'ty	Parts No.	Assembly No.
E-1	Cover for Feed Shaft Bushing (L)	1	140188-0-04		E-21	Washer	1	140208-0-01	
E-2	Packing	1	140187-0-00		E-22	Main Feed Link Shaft (Small)	1	140210-0-01	
E-3	Screw 3.57	3	102538-0-02		E-23	Main Feed Link Bushing	1	140207-0-01	
E-4	Feed Shaft	1	146538-0-01		E-24	Differential Feed Link	1	146554-0-01	
E-5	Oil Cap	2	140327-0-01		E-25	Differential Feed Link Bushing	1	146555-0-01	
E-6	Feed Shaft Bushing (L)	1	146539-0-00		E-26	Washer	1	140208-0-01	
E-7	Feed Arm	1	146533-0-01		E-27	Feed Link Shaft (Large)	1	140217-0-01	
E-8	Bolt 6.35 x 16	1	017771-6-12		E-28	Differential Feed Adjusting Link	1	146556-0-01	
E-9	Oil Cap	1	140326-0-01		E-29	Screw 3.57	1	148834-0-01	
E-10	Pin	1	147318-0-00		E-30-1	Differential Feed Link Lever	1		E-30 Link Lever Assembly 146914-0-01
E-11	Feed Arm Pin	1	146532-0-01		E-30-2	Bolt 6.35 x 14	1	017771-4-12	
E-12-1	Screw 3.18 x 7	2	009660-7-12	E-12 Differential Feed Arm Assembly 146550-0-01	E-31	Packing	1	109203-0-01	
E-12-2	Differential Feed Adjuster Cap	1			E-32	Differential Gear	1	156893-0-01	
E-12-3	Differential Feed Arm	1		E-33	Screw 3.57 x 12	2	007671-2-12		
E-12-4	Differential Feed Adjuster	1		E-34	Switch Lever Plate	1	156913-0-01		
E-12-5	Bolt 6.35 x 14	1	017771-4-12	E-35	Dogs	1	159392-0-01		
E-13	Felt	1	147363-0-00	E-36	Washer 4	1	025340-2-32		
E-14	Main Feed Arm	1	140205-0-01	E-37	Screw 3.57 x 6	1	009670-6-12		
E-15	Bolt 6.35 x 14	1	017771-4-12	E-38	Differential Stitch Control	1	156894-0-01		
E-16	Main Feed Link Shaft (Large)	1	143564-0-01	E-39	Stopper for Differential Stitch Control	2	146563-0-01		
E-17	Washer	1	113431-0-02	E-40	Washer 6.35	2	025770-2-32		
E-18	Nut 4.76	1	143565-0-01	E-41	Bolt 6.35 x 14	2	017771-4-12		
E-19	Feed Shaft Bushing (R)	1	146540-0-00						
E-20	Main Feed Link	1	140209-0-01						

## E. Feed Mechanism (2)

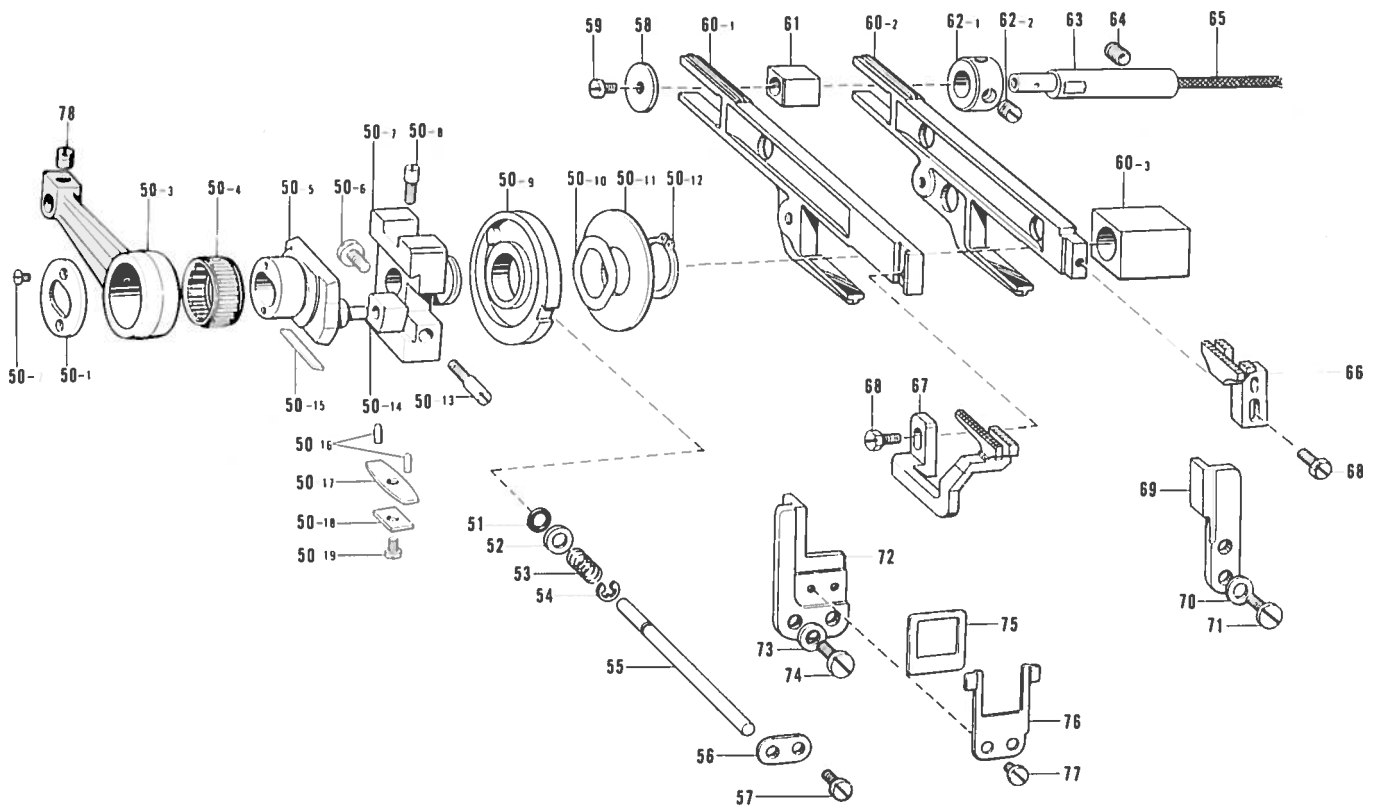

Ref. No.	Name of Parts	Q'ty	Parts No.	Assembly No.	Ref. No.	Name of Parts	Q'ty	Parts No.	Assembly No.
E-50-1	Feed Rod Presser Plate	1	140176-0-01	E-50 Eccentric Wheel Assembly 146528-0-01	E-57	Screw 3.57 x 6	1	009670-6-12	
E-50-2	Screw 2.38	2	117517-0-03		E-58	Slide Plate	1	146549-0-01	
E-50-3	Feed Rod	1	146530-0-01		E-59	Screw 4.37 x 7	1	009680-7-12	
E-50-4	Needle Roller Bearing 20	1	146531-0-01		E-60-1	Differential Feed Bar	1		E-60 Feed Bar Guide Block Assembly 146541-0-01
E-50-5	Eccentric Wheel	1			E-60-2	Main Feed Bar	1		
E-50-6	Screw 4.37	1	107093-0-02		E-60-3	Feed Lifting Slide Block	1	146544-0-00	
E-50-7	Eccentric Wheel Holder	1			E-61	Feed Bar Guide Block	1	146547-0-00	
E-50-8	Screw 4.76	2	100025-0-02		E-62-1	Collar	1		F-62 Collar Assembly 181969-0-03
E-50-9	Eccentric Wheel Adjusting Cam	1	144053-0-01		E-62-2	Screw 6.35	2	101706-0-01	
E-50-10	Spring	1	144055-0-01		E-63	Feed Bar Guide Block Shaft	1	146548-0-01	
E-50-11	Washer	1	146529-0-01		E-64	Screw 6.35 x 6	1	014770-6-22	
E-50-12	Stop Ring C15	1	048150-1-43		E-65	Wick	1	147362-0-00	
E-50-13	Screw 4.37	1	145663-0-01		E-66	Main Feed Dog	1	146567-0-01	
E-50-14	Slide Block	1	140165-0-01		F-67	Differential Feed Dog	1	156895-0-01	
E-50-15	Gib	1	146401-0-01		E-68	Bolt 4.37	2	117516-0-01	
E-50-16	Gib Holder Pin	2	146402-0-01		E-69	Feed Bar Guide (R)	1	148174-0-00	
E-50-17	Gib Holder Plate (L)	1	146404-0-01		E-70	Washer	2	113431-0-02	
E-50-18	Gib Holder Plate (S)	1	146403-0-01		E-71	Screw 4.37	2	107407-0-03	
E-50-19	Screw 3.18 x 5	1	009660-5-02		E-72	Feed Bar Guide (L)	1	149888-0-00	
E-51	Packing	1	118770-0-01	E-73	Washer	2	113431-0-02		
E-52	Washer	1	113431-0-02	E-74	Screw 4.37	2	107407-0-03		
E-53	Spring	1	146535-0-01	E-75	Frangement Protector	1	149886-0-00		
E-54	Stop Ring	1	048040-3-42	E-76	Frangement Protector Plate	1	149887-0-01		
E-55	Feed Adjusting Shaft	1	149405-0-01	E-77	Screw 3.57	2	106568-0-03		
E-56	Supporter for Feed Adjusting Shaft	1	146536-0-01	E-78	Screw 6.35	1	100251-0-01		

# F. Presser Foot Mechanism

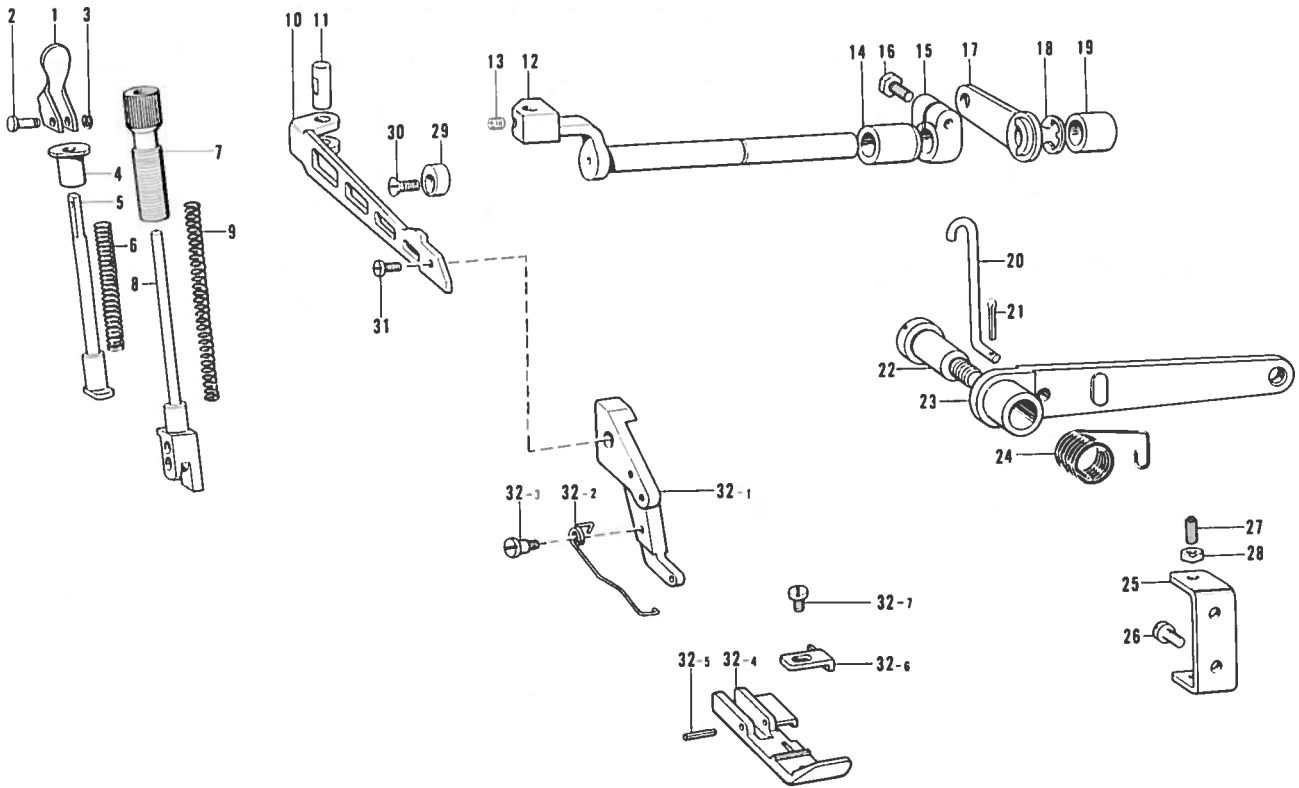

Ref. No.	Name of Parts	Q'ty	Parts No.	Assembly No.	Ref. No.	Name of Parts	Q'ty	Parts No.	Assembly No.
F- 1	Presser Bar Lifter	1	147759-0-01		F-20	Presser Foot Lifter Link	1	146523-0-01	
F- 2	Presser Bar Lifter Pin	1	144084-0-01		F-21	Pin	1	110793-0-01	
F- 3	Stop Ring	1	048020-3-42		F-22	Screw 7.94	1	148372-0-01	
F- 4	Washer	1	144083-0-01		F-23	Presser Foot Lifter Lever	1	143323-1-03	
F- 5	Presser Bar Lifter Shaft	1	144085-0-01		F-24	Spring	1	143325-0-01	
F- 6	Spring	1	144086-0-01		F-25	Adjuster Plate	1	146522-0-01	
F- 7	Screw	1	144079-0-01		F-26	Screw 4.37 x 7	2	009680-7-12	
F- 8	Presser Bar	1	146521-0-01		F-27	Screw 4.76	2	153483-0-01	
F- 9	Spring	1	144081-0-01		F-28	Nut 4.76	2	110161-0-06	
F-10	Main Presser Arm	1	146526-0-01		F-29	Presser Arm Stopper	1	144088-0-01	
F-11	Pin for Presser Arm Shaft	1	146527-0-01		F-30	Screw 4.76	1	107231-0-02	
F-12	Presser Arm Shaft	1	146525-0-01		F-31	Screw 4.37 x 7	1	009680-7-12	
F-13	Screw 4.37 x 4	1	014680-4-22		F-32-1	Sub-Presser Arm	1		
F-14	Bushing	1	140263-0-00		F-32-2	Spring	1	142246-0-01	
F-15	Collar	1	140261-0-01		F-32-3	Screw	1	142247-0-01	
F-16	Bolt 6.35 x 16	1	017771-6-12		F-32-4	Presser Foot	1		
F-17	Presser Foot Lifter Inside Lever	1	146524-0-01		F-32-5	Pin	1	142243-0-00	
F-18	Stop Ring	1	048080-3-42		F-32-6	Chip Guard (3)	1	142245-0-01	
F-19	Bushing (Right)	1	140262-0-00		F-32-7	Screw 2.38 x 3.5	1	009639-3-12	
									F-32 Presser Foot Assembly 156891-0-01

# G. Lubrication

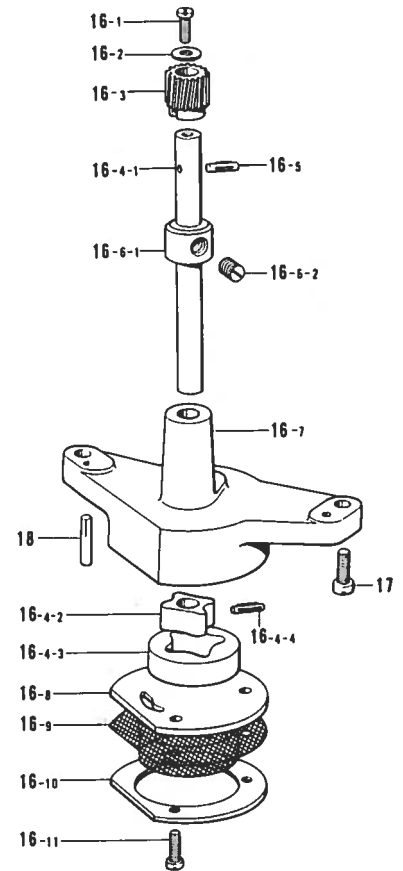
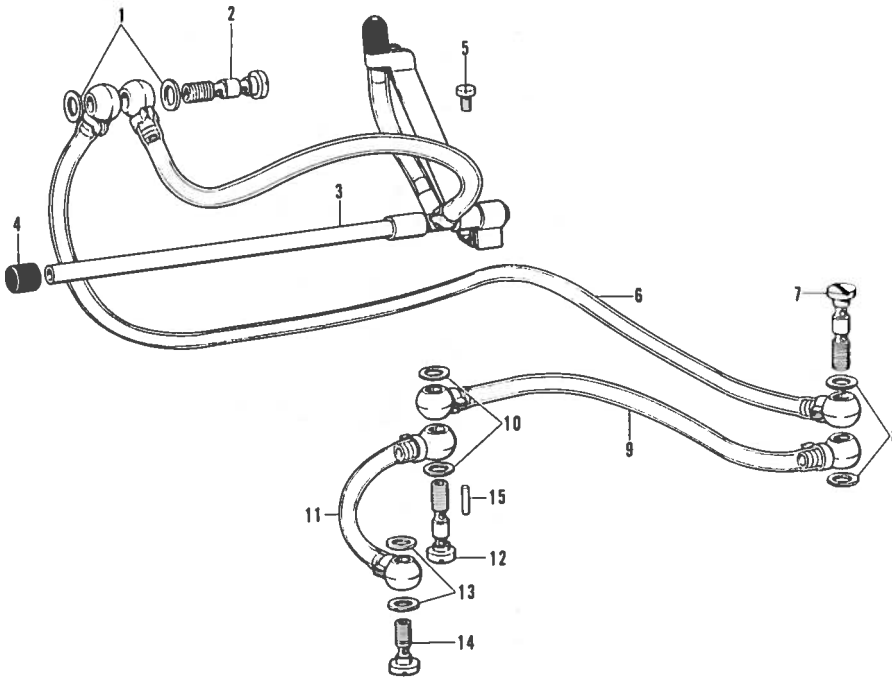

Ref. No.	Name of Parts	Q'ty	Parts No.	Assembly No.	Ref. No.	Name of Parts	Q'ty	Parts No.	Assembly No.
G- 1	Packing	2	112348-0-01		G-16- 2	Washer 3.5	1	025350-3-32	G-16 Pump Assembly 147521-0-01
G- 2	Oil Feeding Pipe (B)	1	112364-0-01		G-16- 3	Worm Wheel	1	144619-0-00	
G- 3	Main Oil Pipe	1	146636-1-01		G-16- 4-1	Pump Inner Roter Shaft	1		G-16-4 Pump Inner Roter Assembly 147523-0-01
G- 4	Oil Cap	1	140325-0-01		G-16- 4-2	Pump Inner Roter	1		
G- 5	Screw 3.57 x 6	1	009670-6-12		G-16- 4-3	Pump Outer Roter	1		
G- 6	Vinyl Tube	1	140780-0-01		G-16- 4-4	Pin	1		
G- 7	Oil Feeding Pipe (B)	1	112364-0-01		G-16- 5	Pin	1	144622-0-01	
G- 8	Packing	2	112348-0-01		G-16- 6-1	Collar	1		G-16-6 Collar Assembly 181995-0-01
G- 9	Vinyl Tube	1	156897-0-01		G-16- 6-2	Screw 6.35	2	101706-0-01	
G-10	Packing	2	112348-0-01		G-16- 7	Pump Case	1		
G-11	Vinyl Tube	1	140778-0-01		G-16- 8	Pump Cover	1	147527-0-01	
G-12	Oil Feeding Pipe (B)	1	112364-0-01		G-16- 9	Oil Filter Gauze	1	147528-0-00	
G-13	Packing	2	112348-0-01		G-16-10	Oil Filter Frange	1	147529-0-01	
G-14	Screw	1	112359-0-01		G-16-11	Screw 3.57 x 10	3	009671-0-12	
G-15	Pin	1	147318-0-00		G-17	Screw 4.76 x 12	2	009711-2-12	
G-16- 1	Screw 3.57 x 8	1	009670-8-12	G-16 147521-0-01	G-18	Pin D3 x 16	2	508693-0-01	

# H. Chain Cutter and Threading

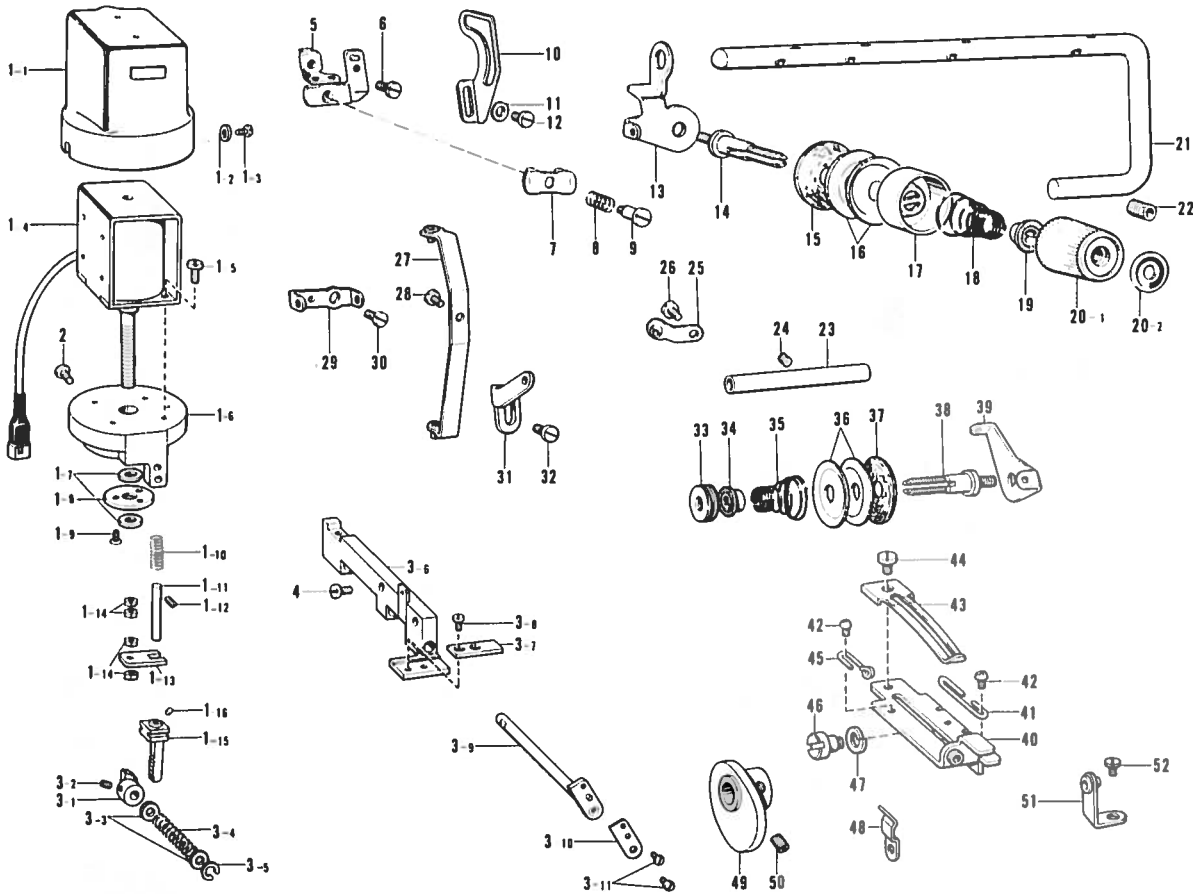

Ref. No.	Name of Parts	Q'ty	Parts No.	Assembly No.	Ref. No.	Name of Parts	Q'ty	Parts No.	Assembly No.
H-1-1	Solenoid Cover Assembly	1	149492-0-01	H-1 Solenoid Driving Mechanism Assembly 149790-0-01	H-18	Spring	1	144104-0-01	H-20 Thread Tension Control Nut Assembly 149568-0-03
H-1-2	Washer	2	113431-0-02		H-19	Tension Spring Washer	1	144105-0-00	
H-1-3	Screw 4.37 x 10	2	009681-0-12		H-20-1	Thread Tension Adjusting Nut	1	149566-0-01	
H-1-4	Solenoid Assembly	1	147364-0-01		H-20-2	Tension Indicating Plate	1	147049-0-03	
H-1-5	Screw 4.37 x 10	4	009681-0-12		H-21	Main Thread Guide	1	146648-0-01	
H-1-6	Solenoid Bracket	1	149491-1-01		H-22	Screw 6.35 x 6	1	014770-6-22	
H-1-7	Plunger Stopper	2	151588-0-00		H-23	Thread Guide Pipe	1	146656-0-01	
H-1-8	Stopper Plate	1	147390-0-01		H-24	Screw 3.18 x 6	1	013660-6-12	
H-1-9	Screw 3.57 x 6	3	009670-6-12		H-25	Chain Stitch Looper Thread Guide	1	151617-0-01	
H-1-10	Spring	1	149789-0-01		H-26	Screw 3.57 x 6	1	009670-6-12	
H-1-11	Guide Bar	1	147393-0-01		H-27	Thread Guide	1	146925-0-01	
H-1-12	Screw 4.37 x 4	1	014680-4-22		H-28	Screw 3.57 x 6	1	009670-6-12	
H-1-13	Guide Plate	1	147794-0-01		H-29	Needle Thread Guide (A)	1	143757-0-01	
H-1-14	Nut 8	4	147986-0-01		H-30	Screw 3.18 x 4	1	009660-4-12	
H-1-15	Rack	1	147391-0-01		H-31	Chain Stitch Needle Thread Guide	1	146650-0-01	
H-1-16	Felt	1	147916-0-00		H-32	Screw 3.57 x 8	1	009670-8-12	
H-2	Screw 5.95 x 16	2	009761-6-12		H-33	Upper Thread Tension Adjusting Screw	1	151012-0-01	
H-3-1	Pinion	1	147403-0-01	H-34	Tension Spring Washer	1	144105-0-00		
H-3-2	Screw 4.37 x 4	2	014680-4-22	H-35	Thread Tension Adjusting Spring	1	147149-0-01		
H-3-3	Washer	2	147792-0-01	H-36	Tension Disc	2	145446-0-01		
H-3-4	Spring	1	149394-0-01	H-37	Felt	1	110832-0-01		
H-3-5	Stop Ring	1	147401-0-01	H-38	Thread Tension Control Stud	1	147148-0-01		
H-3-6	Tape Cutter Bracket	1		H-39	Needle Thread Guide Plate	1	110813-0-01		
H-3-7	Tape Cutter Lower Blade	1	147405-0-01	H-40	Chain Stitch Looper Base Plate	1	150808-0-01		
H-3-8	Screw 3.18 x 4	2	009660-4-12	H-41	Thread Guide (R)	1	146663-0-01		
H-3-9	Tape Cutter Shaft	1		H-42	Screw 2.38 x 4	2	001630-4-02		
H-3-10	Tape Cutter Upper Blade	1	153031-0-01	H-43	Thread Handler	1	150810-0-01		
H-3-11	Screw 3.57 x 5	2	009670-5-12	H-44	Screw 3.57 x 4	1	009670-4-12		
H-4	Screw 3.57 x 10	2	009671-0-12	H-45	Thread Guide (L)	1	150811-0-01		
H-5	Needle Thread Guide	1	147344-0-01	H-46	Screw 4.37	1	150812-0-01		
H-6	Screw 3.57 x 6	1	009670-6-12	H-47	Washer 2-5	1	028050-2-42		
H-7	Needle Thread Guard	1	112300-0-01	H-48	Spring	1	150813-0-01		
H-8	Needle Thread Guide Spring	1	112299-0-01	H-49	Chain Stitch Looper Take-up	1	150807-0-01		
H-9	Screw 3.18	1	112301-0-01	H-50	Screw 4.37 x 4	2	014680-4-22		
H-13	Thread Guide Supporter	1	146649-0-01	H-51	Thread Guide	1	146930-0-01		
H-14	Looper Thread Tension Control Stud	1	110820-0-01	H-52	Screw 3.57 x 6	1	009670-6-12		
H-15	Felt	1	110832-0-01						
H-16	Tension Disc	2	145446-0-01						
H-17	Presser for Tension Disc	1	144103-0-02						

# J. Cloth Control System and Control Box Mechanism

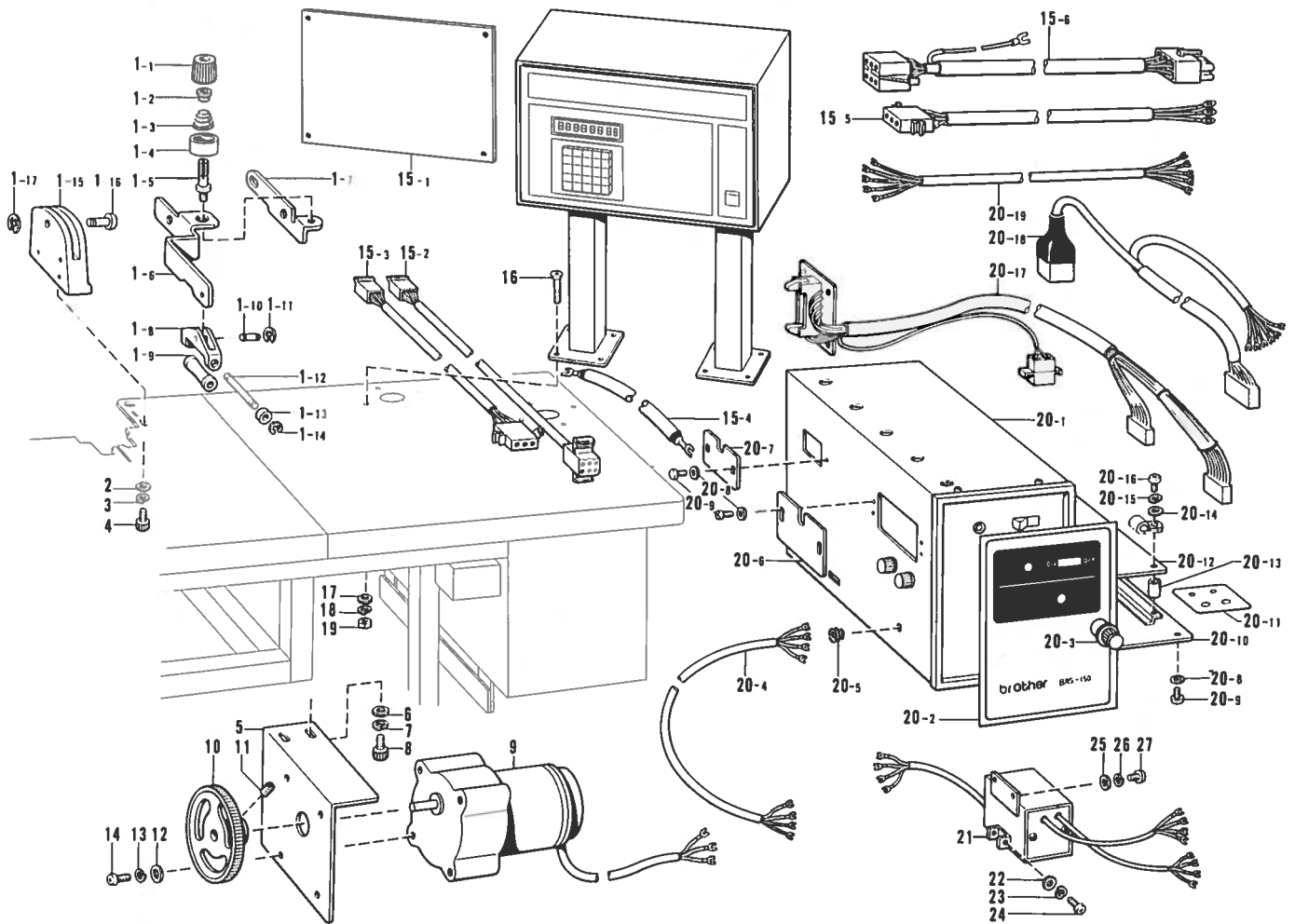

Ref. No.	Name of Parts	Q'ty	Parts No.	Assembly No.	Ref. No.	Name of Parts	Q'ty	Parts No.	Assembly No.
J- 1- 1	Thread Tension Adjusting Nut	1	149566-0-01	J-1 Servo Presser Assembly 156914-0-01	J-15- 4	Earth Wire B	1	156927-0-01	J-15 Operation Box Assembly 156920-0-02
J- 1- 2	Tension Spring Washer	1	144105-0-00		J-15- 5	Power Supply Cord	1	156925-0-01	
J- 1- 3	Spring	1	144104-0-01		J-15- 6	Pulse Motor Cord	1	156923-0-01	
J- 1- 4	Presser for Tension Disc	1	144103-0-02		J-16	Screw 6 x 40	8	149320-0-01	
J- 1- 5	Looper Thread Tension Control Stud	1	110820-0-01		J-17	Washer 6	8	025060-2-32	
J- 1- 6	Presser Plate	1	156915-0-01		J-18	Washer 2-6	8	028060-2-42	
J- 1- 7	Lifting Plate	1	149372-0-01		J-19	Nut 2	8	021060-1-02	
J- 1- 8	Roller Supporter	1	149368-0-01		J-20- 1	Control Box	1		J-20 Control Box Assembly
J- 1- 9	Servo Presser Roller	1	149367-0-00		J-20- 2	Panel Plate	1	156902-0-01	
J- 1-10	Pin	1	149371-0-01		J-20- 3	Volume Adjuster	1	149932-0-01	
J- 1-11	Stop Ring	2	048020-3-42		J-20- 4	Power Supply Cord	1	149900-0-01	
J- 1-12	Roller Shaft	1	149369-0-01		J-20- 5	Rubber Bush	1	149901-0-01	
J- 1-13	Bearing	2	149489-0-01		J-20- 6	Cover B	1	149559-0-01	
J- 1-14	Stop Ring	2	048020-3-42		J-20- 7	Cover A	1	149558-0-01	
J- 1-15	Presser Plate Base	1	149373-0-01		J-20- 8	Washer 4	10	151592-0-01	
J- 1-16	Shaft	1	149374-0-01		J-20- 9	Screw 4 x 10	10	002401-0-03	
J- 1-17	Stop Ring	1	048040-3-42		J-20-10	Mounting Plate	1	149556-0-01	
J- 2	Washer	2	025060-2-32	J-20-11	Cloth Sensor	1	149937-0-01		
J- 3	Washer 2-6	2	028060-2-42	J-20-12	Control Circuit Board	1	159593-0-01		
J- 4	Bolt 6 x 14	2	018061-4-22	J-20-13	Collar	6	149560-0-01		
J- 5	Servo Motor Setting Plate	1	149364-0-01	J-20-14	Washer 3	6	025030-2-33		
J- 6	Washer 6	2	025060-2-32	J-20-15	Washer 2 3	6	028030-2-43		
J- 7	Washer 2 6	2	028060-2-42	J-20-16	Screw 3 x 30	6	002303-0-03		
J- 8	Bolt 6 x 10	2	018061-0-22	J-20-17	Harness A ssembly	1	153328-0-01		
J- 9	Servo Motor	1	149779-0-01	J-20-18	Valve Cord	1	157993-0-01		
J-10	Servo Roller	1	149366-0-01	J-20-19	Motor Lead Wire	1	149990-0-01		
J-11	Screw 4 x 5	2	014400-5-22	J-21	Transformer Box Assembly	1	150493-0-01		
J-12	Washer 4	4	025040-2-32	J-22	Washer 4	2	025040-2-33		
J-13	Washer 2 4	4	028040-2-42	J-23	Washer 2 4	2	028040-2-43		
J-14	Screw 4 x 14	4	002401-4-02	J-24	Screw 4 x 8	2	002400-8-03		
J-15- 1	Control Circuit Board	1	156921-0-01	J-25	Washer 6	2	025060-2-32		
J-15- 2	Synchronizer Cord	1	156924-0-01	J-26	Washer 2 6	2	028060-2-42		
J-15- 3	Original Point Cord	1	158016-0-01	J-27	Bolt 6 x 10	2	018061-0-22		

# K. Air Pressure Mechanism

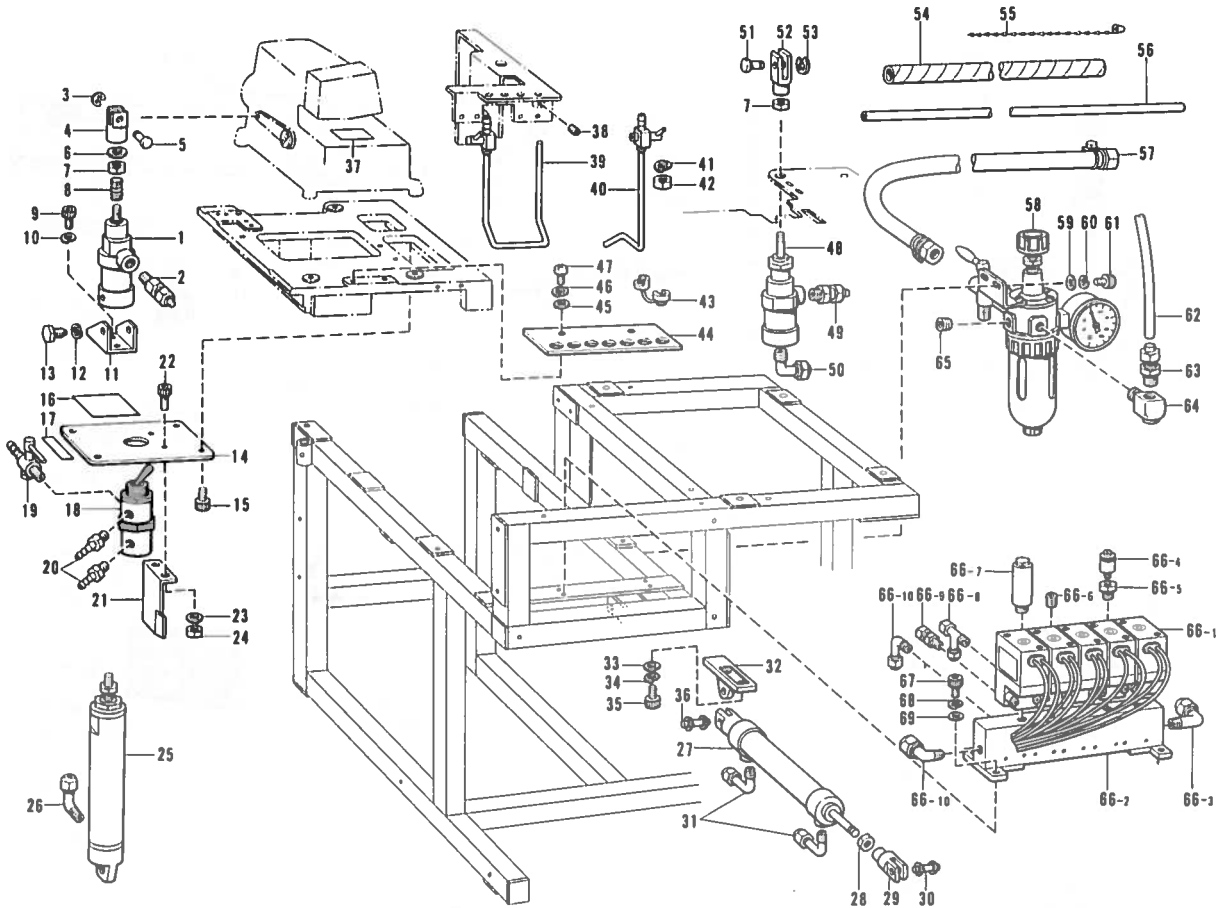

Ref. No.	Name of Parts	Q'ty	Parts No.	Assembly No.	Ref. No.	Name of Parts	Q'ty	Parts No.	Assembly No.
K-1	Cylinder	1	152226-0-00		K-40	Air Pipe (B)	1	153262-0-01	
K-2	Connector	1	149435-0-00		K-41	Washer 2-5	2	028050-2-43	
K-3	Stop Ring	1	048040-3-42		K-42	Nut 5	2	021500-1-03	
K-4	Piston Rod Joint	1	149411-0-01		K-43	Bushing	3	153258-0-00	
K-5	Pin	1	146153-0-01		K-44	Air Pipe Supporter	1	153257-0-01	
K-6	Tension Disc	1	145446-0-01		K-45	Washer 5	2	025050-2-32	
K-7	Nut 6	2	021060-3-06		K-46	Washer 2-5	2	028050-2-42	
K-8	Spring	1	152230-0-01		K-47	Screw 5 x 10	2	002501-0-02	
K-9	Bolt 4 x 8	2	018400-8-22		K-48	Cylinder Assembly	1	151713-0-01	
K-10	Washer 2-4	2	028040-2-42		K-49	Connector	1	149435-0-00	
K-11	Cylinder Bracket	1	151735-0-01		K-50	Elbow 4 - PT 1/8 - BS	1	149503-0-01	
K-12	Washer 2-6	2	028060-2-42		K-51	Pin	1	146153-0-01	
K-13	Screw	2	140620-0-01		K-52	Piston Rod Joint	1	149411-0-01	
K-14	Switch Plate	1	153255-0-01		K-53	Stop Ring	1	048040-3-42	
K-15	Bolt 4 x 8	4	018400-8-22		K-54	Spiral Tube 6	1	149801-0-00	
K-16	Switch Panel	1			K-55	Bead Band	24	340400-0-01	
K-17	Sticker	1			K-56	Air Tube 4 x 2.5	1	153278-0-00	
K-18	Pin Lever Valve	1	153256-0-01		K-57	Air Tube	1	149796-0-01	
K-19	Air Cock	1	151093-0-01		K-58	Air Unit Assembly	1	149576-0-01	
K-20	Connector	2	149506-0-01		K-59	Washer 6	2	025060-2-32	
K-21	Limit Switch Plate	1	149341-0-01		K-60	Washer 2-6	2	028060-2-42	
K-22	Bolt 4 x 8	2	018400-8-22		K-61	Bolt 6 x 8	2	018060-8-22	
K-23	Washer 4	2	025040-2-32		K-62	Air Tube 10 x 6.5	1	149514-0-01	
K-24	Nut 4	2	021400-2-02		K-63	Air Connector	1	149434-0-00	
K-25	Air Cylinder 20 x 25	1	153032-0-01		K-64	Air Joint	1	153252-0-00	
K-26	Elbow 4 - PT 1/8 - BS	1	149503-0-01		K-65	Cap	1	140542-0-01	
K-27	Air Cylinder 30 x 200	1	153253-0-01		K-66-1	Solenoid Valve	5	149508-0-01	
K-28	Nut	1	149488-0-01		K-66-2	Valve Mounting Base	1	157990-0-01	
K-29	Joint	1	149501-0-01		K-66-3	Elbow 10 - PT 1/4	1	153273-0-00	
K-30	Pin Assembly	1	151177-0-01		K-66-4	Adjusting Valve	2	153268-0-01	
K-31	Elbow 4 - PT 1/8 - BS	2	149503-0-01		K-66-5	Bushing	2	157991-0-00	
K-32	Rod Connector	1	153254-0-01		K-66-6	Cap	1	153274-0-01	
K-33	Washer 6	2	025060-2-32		K-66-7	Silencer	2	140682-0-01	
K-34	Washer 2-6	2	028060-2-42		K-66-8	Air Joint PT 1/8	1	151620-0-00	
K-35	Bolt 6 x 20	2	018062-0-22		K-66-9	Air Joint 4 - PT 1/8	3	149435-0-00	
K-36	Pin Assembly	1	151178-0-01		K-66-10	Elbow 4 - PT 1/8 - BS	2	149503-0-01	
K-37	Safety Sticker	1			K-67	Bolt 4 x 10	4	018401-0-22	
K-38	Screw 3 x 5	1	014300-5-22		K-68	Washer 2-4	4	028040-2-42	
K-39	Air Pipe (A)	1	153259-0-01		K-69	Washer 4	4	025040-2-32	

K-66  
Solenoid  
Valve Assembly  
156903-0-01



# L. Power Supply Equipment Mechanism

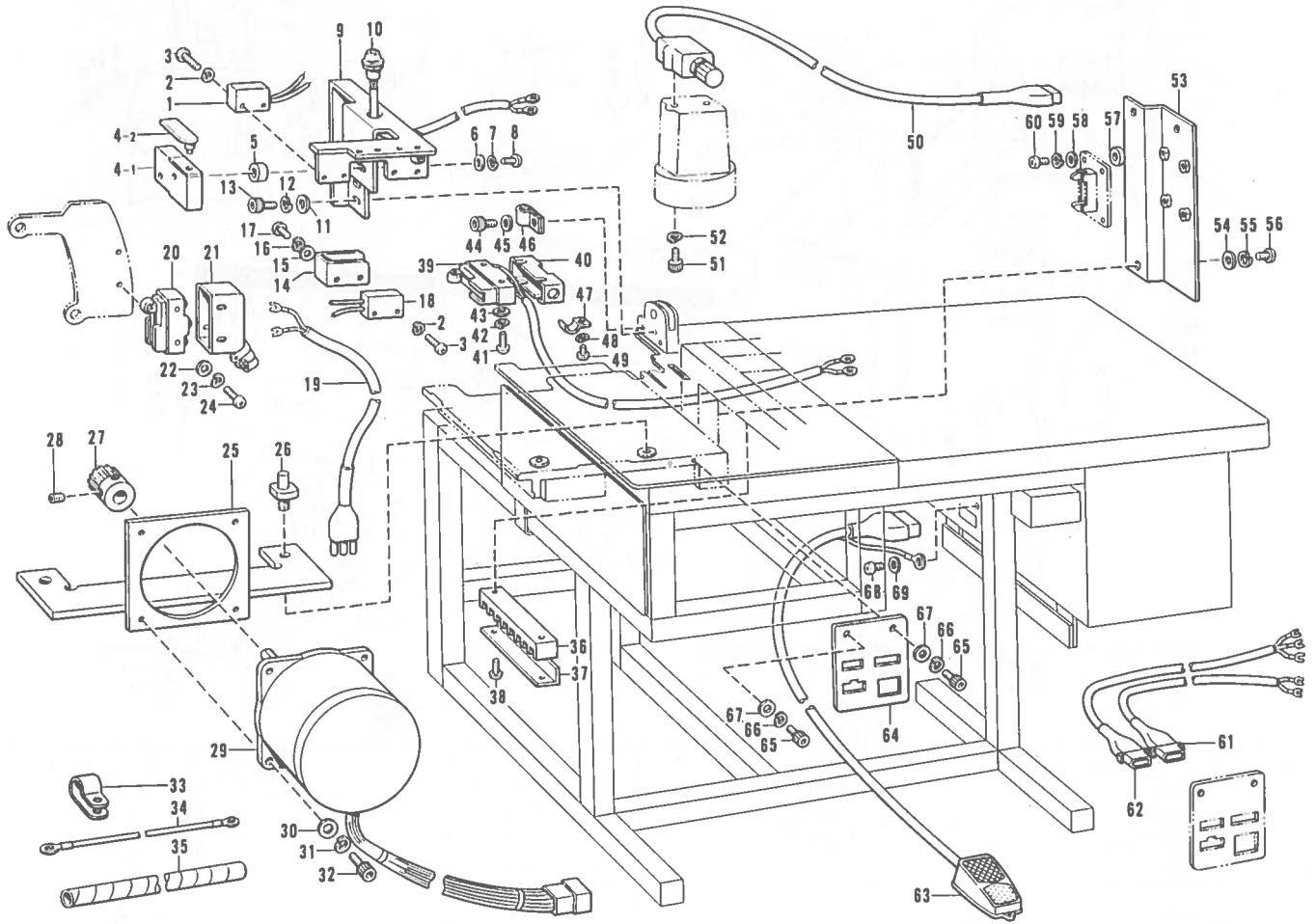

Ref. No.	Name of Parts	Q'ty	Parts No.	Assembly No.	Ref. No.	Name of Parts	Q'ty	Parts No.	Assembly No.
L-1	Photo Sensor Assembly (B)	1	153283-0-01		L-35	Spiral Tube 11	2	156904-0-00	
L-2	Washer 2-3	4	028030-2-43		L-36	Terminal Block	1	149522-0-01	
L-3	Screw 3 x 16	4	002301-6-03		L-37	Cover	1	149916-0-01	
L-4-1	Body	1		L-4 Photo Sensor 149452-0-01	L-38	Screw 4 x 14	2	002401-4-02	
L-4-2	Control Sensor	1			L-39	Micro Switch	1	153287-0-01	
L-5	Collar	2	152364-0-01		L-40	Micro Switch Cover	1	149516-0-01	
L-6	Washer 3	2	025030-2-33		L-41	Screw 4 x 25	1	002402-5-02	
L-7	Washer 2-3	2	028030-2-43		L-42	Washer 2-4	2	028040-2-42	
L-8	Screw 3 x 12	2	002301-2-03		L-43	Washer 4	2	025040-2-32	
L-9	Photo Sensor Mounting Base	1	153280-0-01		L-44	Bolt 4 x 12	1	018401-2-22	
L-10	Led Assembly	1	149810-0-01		L-45	Washer 4	1	025040-2-32	
L-11	Washer 4	2	025040-2-33		L-46	Cord Holder	1	150826-0-00	
L-12	Washer 2-4	2	028040-2-43		L-47	Cord Holder	1	140647-0-01	
L-13	Bolt 4 x 8	2	018400-8-22		L-48	Washer 2-3	1	028030-2-43	
L-14	Sensor Supporter	1	156905-0-01		L-49	Screw 3 x 6	1	002300-6-03	
L-15	Washer 3	2	025030-2-33		L-50	Push Button Assembly	1	149780-0-01	
L-16	Washer 2-3	2	028030-2-43		L-51	Bolt 4 x 8	2	018400-8-22	
L-17	Screw 3 x 6	2	002300-6-03		L-52	Washer 2-4	2	028040-2-43	
L-18	Photo Sensor Assembly (A)	1	153281-0-01		L-53	Board Supporter	1	153451-0-01	
L-19	Limit Switch Cord	1	156912-0-01		L-54	Washer 4	2	025040-2-33	
L-20	Limit Switch	1	156911-0-01		L-55	Washer 2-4	2	028040-2-43	
L-21	Micro Switch Cover	1	147926-0-00		L-56	Screw 4 x 8	2	002400-8-03	
L-22	Washer 4	2	025040-2-32		L-57	Collar (A)	4	149459-0-00	
L-23	Washer 2-4	2	028040-2-42		L-58	Washer 4	4	025040-2-33	
L-24	Screw 4 x 25	2	002402-5-02		L-59	Washer 2-4	4	028040-2-43	
L-25	Stepping Motor Base	1	156909-0-01		L-60	Screw 4 x 12	4	002401-2-03	
L-26	Guide Pin	2	156910-0-01		L-61	Cord Assembly	1	149778-0-01	
L-27	Gear	1	156908-0-01		L-62	Cutter Switch Cord Assembly	1	149925-0-01	
L-28	Screw 6.35	2	014771-0-22		L-63	Foot Switch Assembly	1	150389-0-01	
L-29	Stepping Motor	1	156907-0-01		L-64	Connector Panel	1	156906-0-01	
L-30	Washer 4	4	025040-2-32		L-65	Bolt 4 x 12	2	018400-8-22	
L-31	Washer 2-4	4	028040-2-42		L-66	Spring Washer	2	028040-2-42	
L-32	Bolt 4 x 12	4	018401-2-22		L-67	Washer 4	2	025040-2-32	
L-33	Nylon Clamp	3	149287-0-00		L-68	Screw 3 x 6	1	002300-6-03	
L-34	Earth Wire	1	149906-0-01		L-69	Washer 3	1	025030-2-33	

# M. Table Unite

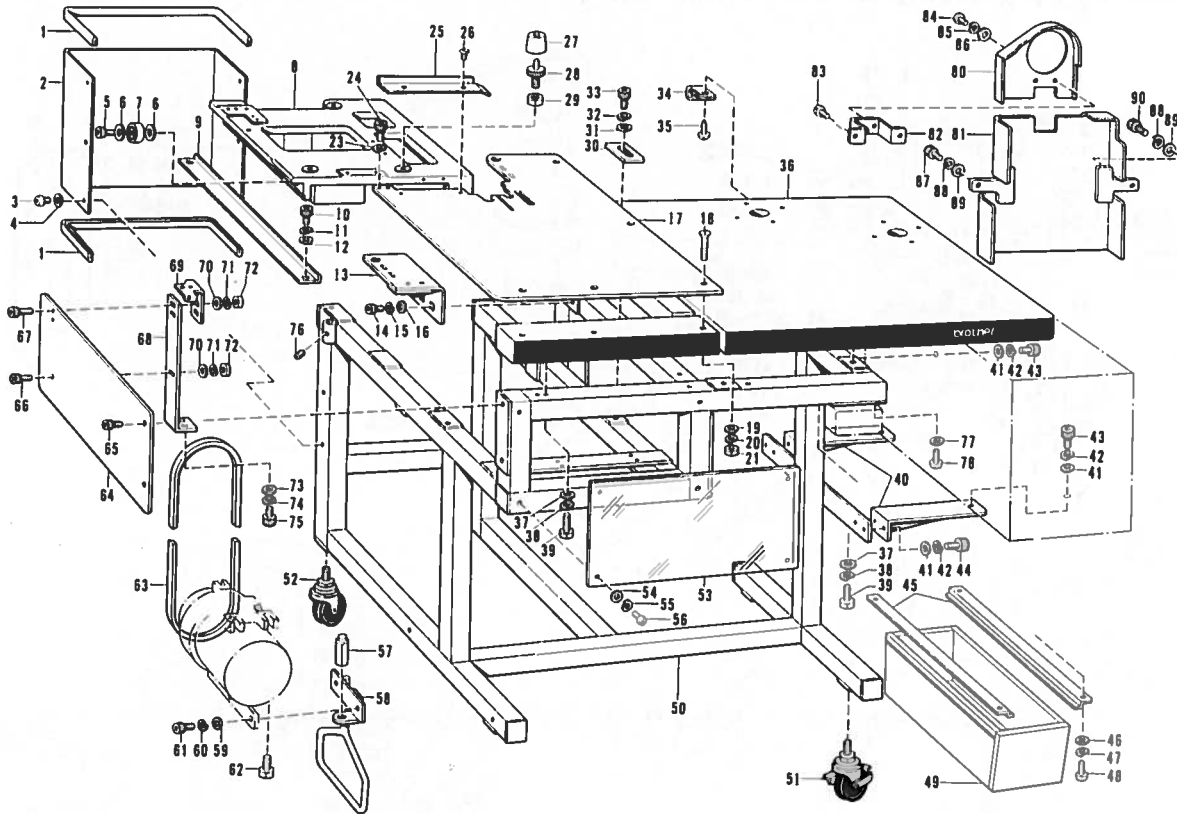

Ref. No.	Name of Parts	Q'ty	Parts No.	Assembly No.	Ref. No.	Name of Parts	Q'ty	Parts No.	Assembly No.
M-1	Frame	2	153307-0-00		M-46	Washer 5	4	025050-2-32	
M-2	Rear Cover	1	153306-0-01		M-47	Washer 2-5	4	028050-2-42	
M-3	Screw 3 x 6	6	002300-6-03		M-48	Screw 5 x 10	4	002501-0-03	
M-4	Washer 3	6	025030-2-33		M-49	Drawer	1	119702-0-02	
M-5	Bolt 10 x 30	3	018103-0-22		M-50	Stand	1	153298-0-01	
M-6	Washer 10	6	025100-2-32		M-51	Caster	3	149353-0-01	
M-7	Bearing 6200DD	3	072620-0-40		M-52	Caster	2	149352-0-01	
M-8	Head Supporter	1	153309-0-01		M-53	Side Cover	1	156919-0-00	
M-9	Rail	1	153304-0-01		M-54	Washer 3	4	025030-2-33	
M-10	Bolt 6 x 10	2	018061-0-22		M-55	Washer 2-3	4	028030-2-43	
M-11	Washer 2-6	2	028060-2-42		M-56	Screw 3 x 8	4	002300-8-03	
M-12	Washer 6	2	025060-2-32		M-57	Clutch Head	1	149397-0-01	
M-13	Cloth Plate Supporter	1	156917-0-01		M-58	Foot Clutch	1	149400-0-01	
M-14	Bolt 6 x 10	2	018061-0-22		M-59	Washer 6	2	025060-2-32	
M-15	Washer 2-6	2	028060-2-42		M-60	Washer 2-6	2	028060-2-42	
M-16	Washer 6	2	025060-2-32		M-61	Bolt 6 x 14	2	018061-4-22	
M-17	Cloth Plate	1	156916-0-01		M-62	Bolt M8 x 55	3	017085-5-02	
M-18	Screw 6 x 40	5	149320-0-01		M-63	V Belt	1		
M-19	Washer 6	5	025060-2-32		M-64	S.P Plate	1	158022-0-01	
M-20	Washer 2-6	5	028060-2-42		M-65	Bolt 6 x 8	2	018060-8-22	
M-21	Nut 6	5	021060-1-02		M-66	Bolt 6 x 14	1	018061-4-22	
M-23	Washer 2-4	2	028040-2-42		M-67	Bolt 6 x 20	2	018062-0-22	
M-24	Bolt 4 x 8	2	018400-8-22		M-68	Plate Supporter	1	153303-0-01	
M-25	Cloth Guide	1	156918-0-01		M-69	Thread Take up Lever Assembly	1	153300-0-01	
M-26	Screw 2.38 x 4	2	003630-4-13		M-70	Washer 6	3	025060-2-32	
M-27	Cushion	4	147919-0-01		M-71	Washer 2-6	3	028060-2-42	
M-28	Adjusting Screw	4	149325-0-01		M-72	Nut 6	3	021060-1-02	
M-29	Nut 10	2	021100-2-02		M-73	Washer 6	2	025060-2-32	
M-30	Position Plate	1	149324-0-01		M-74	Washer 2-6	2	028060-2-42	
M-31	Washer 6	2	025060-2-32		M-75	Bolt 6 x 12	2	018061-2-22	
M-32	Washer 2-6	2	028060-2-42		M-76	Screw 6	2	014060-6-22	
M-33	Bolt 6 x 10	2	018061-0-22		M-77	Washer 5	2	025050-2-32	
M-34	Cord Holder #14	5	552908-0-00		M-78	Screw 5 x 10	2	002501-0-03	
M-35	Screw 4.5 x 20	5	101118-0-01		M-80	Belt Cover (C)	1	158743-0-01	
M-36	Table	1	157988-0-01		M-81	Belt Cover (D)	1	158744-0-01	
M-37	Washer 8	8	025080-2-32		M-82	Bolt Cover Supporter	1	154535-0-01	
M-38	Washer 2-8	8	028080-2-42		M-83	Screw 4.37 x 10	2	009681-0-12	
M-39	Bolt M8 x 55	8	017085-5-02		M-84	Screw 4 x 8	2	002400-8-03	
M-40	Box Supporter	2	149562-0-01		M-85	Washer 2-4	2	028040-2-43	
M-41	Washer 6	7	025060-2-32		M-86	Washer 4	2	025040-2-33	
M-42	Washer 2-6	7	028060-2-42		M-87	Bolt 5 x 8	1	018500-8-22	
M-43	Bolt 6 x 10	3	018061-0-22		M-88	Washer	2	028050-2-42	
M-44	Bolt 6 x 14	4	018061-4-22		M-89	Washer 5	2	025050-2-32	
M-45	Guide Plate	2	149567-0-01		M-90	Bolt 5 x 12	1	018501-2-22	

## Z. Accessories

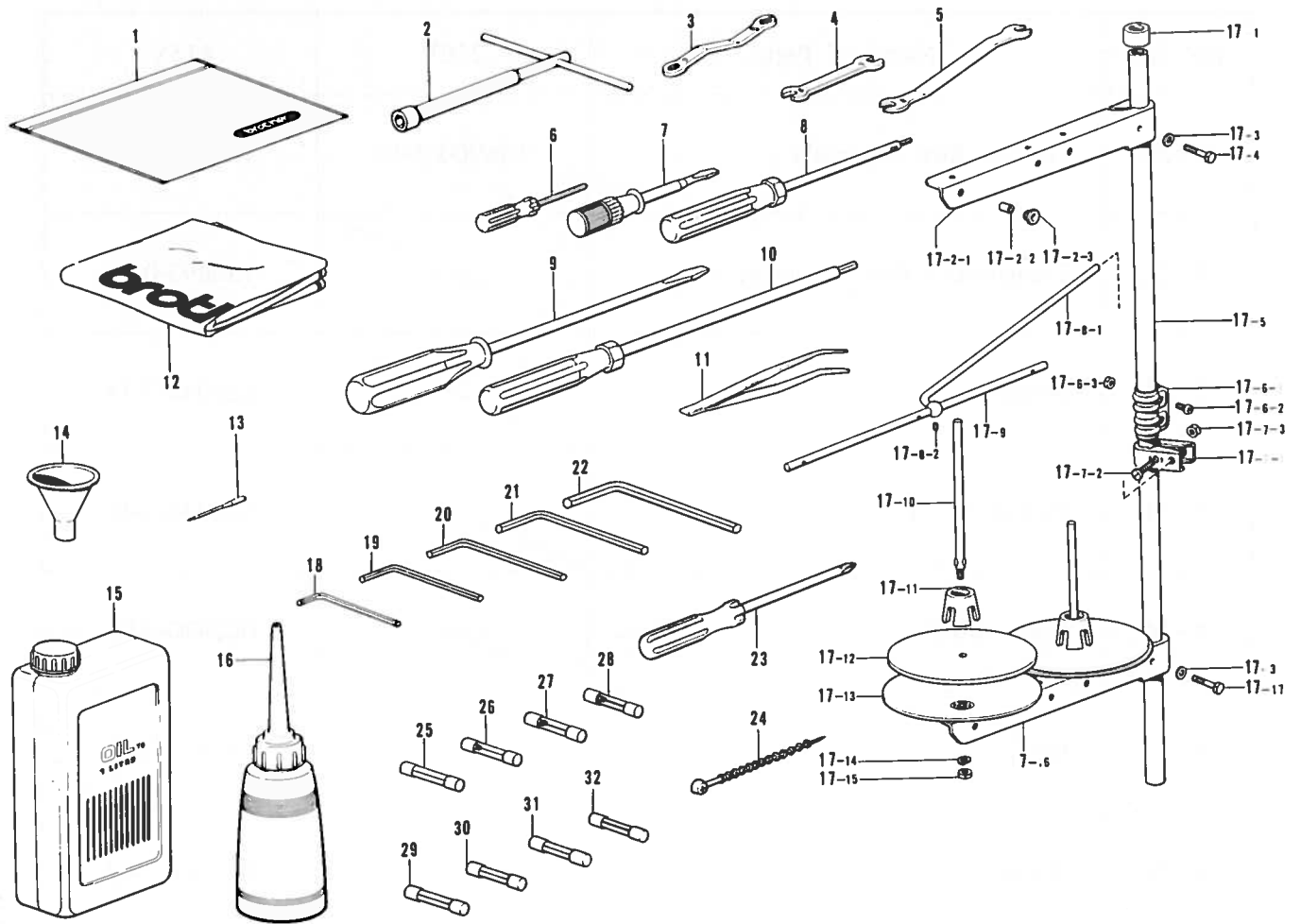

Re. No	Name of Part	Q'ty	Parts No.	Assembly No.	Ref. No.	Name of Parts	Q'ty	Parts No.	Assembly No.
Z- 1	Accessory Bag	1	122991-0-01		Z-17- 8-1	Thread Guide Stopper Bar	1	142996-0-01	Z-17-8 Thread Guide Stopper Bar 142971-0-01
Z- 2	Wrench	1	140342-0-01		Z-17- 8-2	Screw 4.76	1	013719-4-12	
Z- 3	Wrench 8 x 9	1	105343-0-01		Z-17- 9	Thread Guide 3	1	142997-0-01	
Z- 4	Spanner 6 x 7	1	107779-0-01		Z-17-10	Spool Shaft (B)	2	150179-0-01	
Z- 5	Spanner 8	1	143566-0-01		Z-17-11	Spool Cushion	2	126863-0-00	
Z- 6	Screw Driver 1.6	1	144124-0-01		Z-17-12	Spool Mat	2	150182-0-00	
Z- 7	Screw Driver 3.4 x 70	1	118837-0-01		Z-17-13	Spool Stand Base	2	150180-0-00	Z-17 Cotton Stand Assembly 158015-0-01
Z- 8	Screw Driver 2	1	146700-0-01		Z-17-14	Washer 2-5	2	028050-2-43	
Z- 9	Screw Driver 5.5 x 190	1	101572-1-01		Z-17-15	Nut 5	2	021500-1-03	
Z-10	Screw Driver 3	1	149173-0-01		Z-17-16	Spool Holder 2	1	150178-0-01	
Z-11	Tweezers	1	11746 -0-00		Z-17-17	Bolt 5 x 28	1	017502-8-03	
Z-12	Head Cover	1	14422 0-02		Z-18	Spanner 3	1	142721-0-01	
Z-13	Needle DM x 13 #14	4	140104 0-14		Z-19	Spanner 4	1	118064-0-01	
Z-14	Funnel	1	140759-0-00		Z-20	Spanner 5	1	147487-0-01	
Z-15	Oil Tank	1	145277-1-04		Z-21	Spanner 6	1	115157-0-01	
Z-16	Oiler	1	114483-0-02		Z-22	Spanner 8	1	150336-0-01	
Z-17- 1	Cap	1	150174-0-00		Z-23	Screw Driver No. 2	1	150332-0-01	
Z-17- 2-1	Spool Holder 2	1	150178-0 01	Z-17-2 Thread Hanger Assembly 147055 0-03	Z-24	Bead Band	4	340400-0-01	
Z-17 2-2	Thread Bushing	2	142990-0-01		Z-25	Fuse	1	141032-0-00	
Z-17- 2-3	Thread Hanger	2			Z-26	Fuse 2ASB	1	150329-0-00	
Z-17 3	Washer 5	2	025050-2-33	Z-17 Cotton Stand Assembly 158015-0-01	Z-27	Fuse 3ASB	1	150330-0-00	
Z-17- 4	Bolt 5 x 28	1	017502-8-03		Z-28	Fuse 4ASB	1	150331-0-00	
Z-17- 5	Pip	2	150172-0-01		Z-29	Fuse 0.5A	1	151827-0-00	
Z-17- 6-1	Joint	1		Z-17-6 Joint for Cotton Stand Assembly 150106-0-01	Z-30	Fuse D	1	152567-0-00	
Z-17- 6-2	Screw 5 x 14	2	150202-0-01		Z-31	Fuse B	1	152565-0-00	
Z-17- 6-3	Nut 5	2	021500-1-03		Z-32	Fuse 20A	1	158378-0-00	
Z-17- 7-1	Thread Guide Holder	1	150185-0-01	Z-17-7 Thread Guide Holder Assembly 150145-0-01					
Z-17- 7-2	Bolt 5 x 28	1	017502-8-03						
Z-17- 7-3	Nut 5	1	021500-1-03						

\* The details of included accessories are subject to change.

\* Änderungen in der Aufstellung der mitgelieferten Zubehöre sind vorbehalten.

\* Les détails des accessoires inclus sont sujets à des changements.

\* Los detalles de los accesorios incluidos pueden variar.

## DIFFERENT PARTS LIST

Ref. No.	Name of Parts	220V	415V
J - 20	Control Bòx Assembly	156900-0-02	158019-0-01
J - 21	Transformer Box Assembly	/	150493-0-01
J - 22	Washer 4	/	025040-2-33
J - 23	Washer 2 - 4	/	028040-2-43
J - 24	Screw 4 x 8	/	002400-8-03
J - 25	Washer 6	/	025060-2-32
J - 26	Washer 2 - 6	/	028060-2-42
J - 27	Bolt 6 x 10	/	018061-0-22

Ref. No.	Name of Parts	Spm	4000 Spm
M - 63	V Belt (inch)	50 Hz	082103-8-90 (M - 38)
		60 Hz	082103-7-90 (M - 37)

# INDEX

Parts No.	Ref. No.	Remark	Parts No.	Ref. No.	Remark	Parts No.	Ref. No.	Remark	Parts No.	Ref. No.	Remark
001630-4-02	H-42		009761-6-12	H- 2		021060-3-06	K- 7		028040-2-43	L-12	
001680-5-12	B-27		013660-6-12	H-24		021100-2-02	M-29			L-52	
	B-29		013679-4-12	B-14		021400-2-02	K-24			L-55	
002300-6-03	L-17		013719-4-12	C- 6		021500-1-03	K-42			L-59	
	L-49			Z-17- 8- 2			Z-17- 6- 3			M-85	
	L-68		013761-4-10	C-15			Z-17- 7- 3		028050-2-42	H-47	
	M- 3		014060-6-22	M-76			Z-17-15			K-46	
002300-8-03	M-56		014300-5-22	K-38		025030-2-33	J-20-14			M-47	
002301-2-03	L- 8		014400-5-22	J-11			L- 6			M-88	
002301-6-03	L- 3		014680-4-22	A-21			L-15		028050-2-43	K-41	
002303-0-03	J-20-16			D-15			L-69			Z-17-14	
002400-8-03	J-24			F-13			M- 4		028060-2-42	J- 3	
	L-56			H- 1-12			M-54			J- 7	
	M-84			H- 3- 2		025030-3-35	C-25- 3			J-18	
002401-0-03	J-20- 9			H-50		025040-1-35	C-25- 9			J-26	
002401-2-03	L-60		014770-6-22	C-12			C-25-14			K-12	
002401-4-02	J-14			D- 1- 4		025040-2-32	J-12			K-34	
	L-38			D-27- 2			K-23			K-60	
002402-5-02	L-24			E-64			K-69			M-11	
	L-41			H-22			L-22			M-15	
002501-0-02	K-47		014771-0-22	L-28			L-30			M-20	
002501-0-03	C-31		017085-5-02	M-39			L-43			M-32	
	M-48			M-62			L-45			M-42	
	M-78		017502-8-03	Z-17- 4			L-67			M-60	
003630-4-13	M-26			Z-17- 7- 2		025040-2-33	J-22			M-71	
003670-6-14	A-45			Z-17-17			L-11			M-74	
007671-2-12	E-33		017771-4-12	B-46			L-54		028060-2-43	C-25-12	
009639-3-12	F-32- 7			E-12- 5			L-58		028080-2-42	M-38	
009660-4-12	D- 4			E-15			M-86		047140-8-42	A-28- 7	
	H- 3- 8			E-30- 2		025040-3-35	C-25- 6		048020-3-42	F- 3	
	H-30			F-41		025050-2-32	K-45			J- 1-11	
009660-5-02	E-50-19		017771-6-12	A-41			M-46			J- 1-14	
009660-7-12	F-12- 1			B- 1- 2			M-77		048040-3-42	E-54	
009670-4-12	A-28- 4			B-21			M-89			J- 1-17	
	H-44			D- 2		025050-2-33	Z-17- 3			K- 3	
009670-5-12	H- 3-11			D-26		025060-2-32	J- 2			K-53	
009670-6-12	A- 8			F- 8			J- 6		048080-3-42	F-18	
	A-43			F-16			J-17		048150-1-43	E-50-12	
	B-32		018060-8-22	K-61			J-25		072600-0-00	C- 4	
	F-37			M-65			K-33		072600-1-00	C-20	
	E-57		018061-0-22	J- 8			K-59		072620-0-40	M- 7	
	G- 5			J-27			M-12		082103-7-90	M-63	
	H- 1- 9			M-10			M-16		082103-8-90	M-63	
	H- 6			M-14			M-19		100025-0-02	E-50- 8	
	H-26			M-33			M-31		100032-0-03	B-36	
	H-28			M-43			M-41		100251-0-01	E-78	
	H-52		018061-2-22	M-75			M-59		100366-0-01	B-19	
009670-8-12	B- 2		018061-4-22	J- 4			M-70			B-20- 2	
	C- 3			M-44			M-73		101118-0-01	M-35	
	G-16- 1			M-61		025060-3-35	C-25-11		101572-1-01	Z- 9	
	H-32			M-66		020508-2-32	M-37		101706-0-01	E-62- 2	
009671-0-12	G-16-11		018061-6-22	B-30		025100-2-32	M- 6			G-16- 6- 2	
	H- 4		018062-0-22	K-35		025340-2-32	E-36		102538-0-02	C-24	
009680-7-12	A- 2			M-67		025350-3-32	G-16- 2			E- 3	
	A-48		018103-0-22	M- 5		025770-2-32	E-40		102627-0-01	B-45	
	A-53		018400-8-22	K- 9		028030-2-43	J-20-15		102843-0-04	A- 6	
	B- 6			K-15			L- 2		105078-0-01	B- 3	
	B-34			K-22			L- 7		105079-0-01	B- 5	
	E-59			L-13			L-16		105343-0-01	Z- 3	
	F-26			L-51			L-48		106568-0-03	E-77	
	F-31			L-65			M-55		107093-0-02	E-50- 6	
009681-0-12	A-52			M-24		028040-2-42	J-13		107231-0-02	F-30	
	C-19		018401-0-22	K-67			K-10		107244-0-01	C-23	
	C-28		018401-2-22	L-32			K-68		107407-0-03	A-29	
	H- 1- 3			L-44			L-23			B-40	
	H- 1- 5		018500-8-22	M-87			L-31			E-71	
	M-83		018501-2-22	M-90			L-42			E-74	
009681-4-12	A-17		021060-1-02	J-19			L-66		107779-0-01	Z- 4	
009711-2-12	G-17			M-21			M-23		108520-0-01	A-59	
009711-4-12	C-26			M-72		028040-2-43	J-23		109203-0-01	A-37	

Parts No.	Ref. No.	Remark	Parts No.	Ref. No.	Remark	Parts No.	Ref. No.	Remark	Parts No.	Ref. No.	Remark
109203-0-01	E-31		140180-0-01	C-16		144124-0-01	Z- 6		146538-0-01	E- 4	
110161-0-06	D-25		140187-0-00	E- 2		144225-0-02	Z-12		146539-0-00	E- 6	
	F-28		140188-0-04	E- 1		144619-0-00	G-16- 3		146540-0-00	E-19	
110641-0-01	A-36		140205-0-01	E-14		144622-0-01	G-16- 5		146541-0-01	E-60	
110668-0-01	C-10		140207-0-01	E-23		145277-1-04	Z-15		146544-0-00	E-60- 3	
110670-0-00	C-18		140208-0-01	E-21		145446-0-01	H-16		146547-0-00	E-61	
110672-0-00	C-21			E-26			H-36		146548-0-01	E-63	
110673-0-00	C-22		140209-0-01	E-20			K- 6		146549-0-01	E-58	
110778-0-02	D-18		140210-0-01	E-22		145663-0-01	E-50-13		146550-0-01	E-12	
110793-0-01	F-21		140217-0-01	E-27		145664-0-00	A-62		146554-0-01	E-24	
110813-0-01	H-39		140261-0-01	F-15		146153-0-01	K- 5		146555-0-01	E-25	
110820-0-01	H-14		140262-0-00	F-19			K-51		146556-0-01	E-28	
	J- 1- 5		140263-0-00	F-14		146315-0-00	A-31		146563-0-01	E-39	
110832-0-01	H-15		140313-0-01	D-17		146401-0-01	E-50-15		146567-0-01	E-66	
	H-37		140325-0-01	G- 4		146402-0-01	E-50-16		146582-0-01	B-39	
111486-0-01	A-49		140326-0-01	B- 7		146403-0-01	E-50-18		146583-0-01	B-41	
112299-0-01	H- 8			E- 9		146404-0-01	E-50-17		146584-0-01	B-47	
112300-0-01	H- 7		140327-0-01	A-32		146419-0-01	A-15		146586-0-00	B-48	
112301-0-01	H- 9			B-24		146420-0-00	A-16		146618-0-01	D- 1	
112348-0-01	G- 1			D- 5		146421-0-00	A-18		146622-0-01	D- 3	
	G- 8			E- 5		146422-0-01	A- 1		146624-1-01	D-28	
	G-10		140342-0-01	Z- 2		146423-0-01	A-50		146626-0-01	D-24	
	G-13		140415-0-00	B- 4		146424-0-00	A-51		146627-0-01	D-23	
112359-0-01	G-14		140418-0-00	B- 8		146425-0-01	A- 9		146628-0-01	D-21	
112364-0-01	G- 2		140421-0-01	A-57		146426-0-00	A-10		146629-0-00	D-20	
	G- 7		140542-0-01	K-65		146427-0-01	A-11		146630-0-01	D-19	
	G-12			K-66-11			B-11- 2		146631-0-01	D- 6	
112436-0-01	B-42		140620-0-01	K-13		146428-0-01	A- 4		146632-0-01	D- 9	
112735-0-00	A-66		140647-0-01	L-47		146432-0-01	A- 7		146633-0-00	D- 8	
113431-0-02	A-54		140682-0-01	K-66- 7		146433-0-00	A- 5		146634-0-01	D-12	
	C-29		140759-0-00	Z-14		146434-0-00	A-46		146635-0-01	D-16	
	E-17		140778-0-01	G-11		146435-0-00	A-47		146636-1-01	G- 3	
	E-52		140780-0-01	G- 6		146440-0-01	A-28- 6		146647-0-01	C-11	
	E-70		141032-0-00	Z-25		146441-0-00	A-28- 8		146648-0-01	H-21	
	E-73		142243-0-00	F-32- 5		146442-0-01	A-28- 2		146649-0-01	H-13	
	H- 1- 2		142245-0-01	F-32- 6		146444-0-01	A-23		146650-0-01	H-31	
113589-0-01	A-19		142246-0-01	F-32- 2		146446-0-01	A-25		146656-0-01	H-23	
114255-0-02	B-16		142247-0-01	F-32- 3		146457-0-01	A-42		146663-0-01	H-41	
114294-0-01	C- 7		142274-0-01	A-58		146458-0-01	A-39		146700-0-01	Z- 8	
114483-0-02	Z-16		142721-0-01	Z-18		146463-0-01	A-27		146914-0-01	E-30	
115157-0-01	Z-21		142971-0-01	Z-17- 8		146473-0-01	C- 8		146924-0-00	A-23- 2	
117160-0-01	A-24		142990-0-01	Z-17- 2- 2		146476-1-01	B-20		146925-0-01	H-27	
117466-0-00	Z-11		142996-0-01	Z-17- 8- 1		146478-0-01	B-20- 3		146930-0-01	H-51	
117515-0-01	B-43		142997-0-01	Z-17- 9		146479-0-01	B-22		147049-0-03	H-20- 2	
117516-0-01	B-44		143179-0-00	C- 9		146480-0-01	B- 1		147055-0-03	Z-17- 2	
	E-68		143196-0-01	A-22		146482-0-01	B- 1- 3		147148-0-01	H-38	
117517-0-03	E-50- 2		143312-0-00	C- 2		146483-0-01	B- 9		147149-0-01	H-35	
118064-0-01	Z-19		143323-1-03	F-23		146484-0-01	B-15		147217-0-00	A-65	
118770-0-01	E-51		143325-0-01	F-24		146485-0-00	B-13		147318-0-00	D-10	
118837-0-01	Z- 7		143564-0-01	E-16		146486-0-00	B-10			E-10	
119702-0-02	M-49		143565-0-01	E-18		146489-0-01	B-11		G-15		
120990-0-01	D- 7		143566-0-01	Z- 5		146493-0-02	B-25		147344-0-01	H- 5	
122991-0-02	Z- 1		143757-0-01	H-29		146495-0-01	B-28		147361-0-00	A-63	
123185-0-01	A-26		143992-0-01	A- 3		146496-2-01	B-31		147362-0-00	E-65	
126863-0-00	Z-17-11		144053-0-01	E-50- 9		146497-1-01	B-33		147363-0-00	E-13	
140065-0-01	A-34		144055-0-01	E-50-10		146521-0-01	F- 8		147364-0-01	H- 1- 4	
140066-0-01	A-55		144079-0-01	F- 7		146522-0-01	F-25		147390-0-01	H- 1- 8	
140077-0-01	A-40		144081-0-01	F- 9		146523-0-01	F-20		147391-0-01	H- 1-15	
140084-0-00	C-13		144083-0-01	F- 4		146524-0-01	F-17		147393-0-01	H- 1-11	
140088-0-01	B-20- 1		144084-0-01	F- 2		146525-0-01	F-12		147401-0-01	H- 3- 5	
140091-0-00	B-23		144085-0-01	F- 5		146526-0-01	F-10		147403-0-01	H- 3- 1	
140092-0-01	B-18		144086-0-01	F- 6		146527-0-01	F-11		147405-0-01	H- 3- 7	
140093-0-00	B-17		144088-0-01	F-29		146528-0-01	E-50		147415-0-01	C-17	
140096-0-01	B- 1- 4		144103-0-02	H-17		146529-0-01	E-50-11		147487-0-01	Z-20	
140104-0-14	B-12			J- 1- 4		146530-0-01	E-50- 3		147521-0-01	G-16	
	Z-13		144104-0-01	H-18		146531-0-01	E-50- 4		147523-0-01	G-16- 4	
140150-0-00	D-22			J- 1- 3		146532-0-01	E-11		147527-0-01	G-16- 8	
140159-0-00	D-11		144105-0-00	H-19		146533-0-01	E- 7		147528-0-00	G-16- 9	
140165-0-01	E-50-14			H-34		146535-0-01	E-53		147529-0-01	G-16-10	
140176-0-01	E-50- 1			J- 1- 2		146536-0-01	E-56		147691-0-00	D- 1- 6	

Parts No.	Ref. No.	Remark	Parts No.	Ref. No.	Remark	Parts No.	Ref. No.	Remark	Parts No.	Ref. No.	Remark
147759-0-01	F- 1		149562-0-01	M-40		152230-0-01	K- 8		156927-0-01	J-15- 4	
147792-0-01	H- 3- 3		149566-0-01	H-20- 1		152364-0-01	L- 5		157988-0-01	M-36	
147794-0-01	H- 1-13			J- 1- 1		152565-0-00	Z-31		157990-0-01	K-66- 2	
147916-0-00	H- 1-16		149567-0-01	M-45		152567-0-00	Z-30		157991-0-00	K-66- 5	
147919-0-01	M-27		149568-0-03	H-20		153031-0-01	H- 3-10		157992-0-01	C-27	
147926-0-00	L-21		149576-0-01	K-58		153032-0-01	K-25		157993-0-01	J-20-18	
147986-0-01	H- 1-14		149778-0-01	L-61		153252-0-00	K-64		158015-0-01	Z-17	
147988-0-01	D-27		149779-0-01	J- 9		153253-0-01	K-27		158016-0-01	J-15- 3	
148084-0-01	A-20		149780-0-01	L-50		153254-0-01	K-32		158019-0-01	J-20	
148174-0-00	I-69		149789-0-01	H- 1-10		153255-0-01	K-14		158022-0-01	M-64	
148372-0-01	F-22		149790-0-01	H- 1		153256-0-01	K-18		158378-0-00	Z-32	
148425-0-01	B-20- 5		149796-0-01	K-57		153257-0-01	K-44		158743-0-01	M-80	
	D- 1- 2		149801-0-00	K-54		153258-0-00	K-43		158744-0-01	M-81	
	D-28- 2		149810-0-01	L-10		153259-0-01	K-39		159392-0-01	E-35	
148782-0-01	D-14		149886-0-00	E-75		153262-0-01	K-40		159393-0-01	A-44	
148834-0-01	E-29		149887-0-01	E-76		153268-0-01	K-66- 4		181995-0-03	E-62	
148984-0-01	A-28- 5		149888-0-00	E-72		153273-0-00	K-66- 3		181995-0-01	G-16- 6	
148997-0-01	A-28		149900-0-01	J-20- 4		153274-0-01	K-66- 6		215080-0-01	C-25-10	
149171-0-01	D-13		149901-0-01	J-20- 5		153278-0-00	K-56			C-25-15	
149173-0-01	Z-10		149906-0-01	L-34		153280-0-01	L- 9		215083-0-01	C-25- 2	
149287-0-00	L-33		149916-0-01	L-37		153281-0-01	L-18		216880-0-01	C-25-13	
149320-0-01	J-16		149925-0-01	L-62		153283-0-01	L- 1		217093-0-01	C-25- 7	
149320-0-01	M-18		149932-0-01	J-20- 3		153287-0-01	L-39		220067-0-01	C-25	
149324-0-01	M-30		149937-0-01	J-20-11		153298-0-01	M-50		340400-0-01	K-55	
149325-0-01	M-28		149990-0-01	J-20-19		153300-0-01	M-69			Z-24	
149341-0-01	K-21		150106-0-01	Z-17- 6		153303-0-01	M-68		508693-0-01	G-18	
149352-0-01	M-52		150145-0-01	Z-17- 7		153304-0-01	M- 9		552908-0-00	M-34	
149353-0-01	M-51		150172-0-01	Z-17- 5		153306-0-01	M- 2				
149364-0-01	J- 5		150174-0-00	Z-17- 1		153307-0-00	M- 1		156921-0-01	J-15-1	
149366-0-01	J-10		150178-0-01	Z-17- 2- 1		153309-0-01	M- 8		159593-0-01	J-20-12	
149367-0-00	J- 1- 9			Z-17-16							
149368-0-01	J- 1- 8		150179-0-01	Z-17-10		153328-0-01	J-20-17				
149369-0-01	J- 1-12		150180-0-00	Z-17-13		153451-0-01	L-53				
149371-0-01	J- 1-10		150182-0-00	Z-17-12		153483-0-01	F-27				
149372-0-01	J- 1- 7		150185-0-01	Z-17- 7- 1		153484-0-01	D-29				
149373-0-01	J- 1-15		150202-0-01	Z-17- 6- 2		154535-0-01	M-82				
149374-0-01	J- 1-16		150307-0-00	A-64		154841-0-01	A-60				
149392-0-01	H- 3		150329-0-00	Z-26		156886-0-01	A-61				
149394-0-01	H- 3- 4		150330-0-00	Z-27		156887-0-01	A-56				
149397-0-01	M-57		150331-0-00	Z-28		156888-0-01	C- 5				
149400-0-01	M-58		150332-0-01	Z-23		156889-0-01	B-35				
149405-0-01	I-55		150336-0-01	Z-22		156891-0-01	I-32				
149409-0-01	B-26		150389-0-01	L-63		156893-0-01	E-32				
149411-0-01	K- 4		150391-0-02	K-37		156894-0-01	E-38				
	K-52		150392-0-02	K-17		156895-0-01	E-67				
149434-0-00	K-63		150493-0-01	J-21		156897-0-01	G- 9				
149435-0-00	K- 2		150806-0-01	C- 1		156899-0-01	C- 5				
	K-49		150807-0-01	H-49		156900-0-02	J-20				
	K-66- 9		150808-0-01	H-40		156902-0-01	J-20- 2				
149452-0-01	L- 4		150810-0-01	H-43		156903-0-01	K-66				
149459-0-00	L-57		150811-0-01	H-45		156904-0-00	L-35				
149488-0-01	K-28		150812-0-01	H-46		156905-0-01	L-14				
149489-0-01	J- 1-13		150813-0-01	H-48		156906-0-01	L-64				
149491-1-01	H- 1- 6		150826-0-00	L-46		156907-0-01	L-29				
149492-0-01	H- 1- 1		151012-0-01	H-33		156908-0-01	L-27				
149501-0-01	K-29		151059-0-01	A-35		156909-0-01	L-25				
149503-0-01	K-26		151060-0-00	A-38		156910-0-01	L-26				
	K-31		151068-0-01	C-14		156911-0-01	L-20				
	K-50		151093-0-01	K-19		156912-0-01	L-19				
	K-66-10		151177-0-01	K-30		156913-0-01	E-34				
149506-0-01	K-20		151178-0-01	K-36		156914-0-01	J- 1				
149508-0-01	K-66- 1		151588-0-00	H- 1- 7		156915-0-01	J- 1- 6				
149514-0-01	K-62		151592-0-01	J-20- 8		156916-0-01	M-17				
149516-0-01	L-40		151617-0-01	H-25		156917-0-01	M-13				
149522-0-01	L-36		151620-0-00	K-66- 8		156918-0-01	M-25				
149547-0-00	C-30		151713-0-01	K-48		156919-0-00	M-53				
149556-0-01	J-20-10		151735-0-01	K-11		156920-0-02	J-15- 1				
149558-0-01	J-20- 7		151827-0-00	Z-29		156923-0-01	J-15- 6				
149559-0-01	J-20- 6		152194-0-01	A-28- 3		156924-0-01	J-15- 2				
149560-0-01	J-20-13		152226-0-00	K- 1		156925-0-01	J-15- 5				

**brother®**

151-150  
195150-0-02  
May, 1982  
Printed in Japan

From the library of: Diamond Needle Corp